

日規半密式螺桿 直線電缸滑台

JP. SEMI SEALED
SPINDLE AXES
LINEAR ACTUATORS

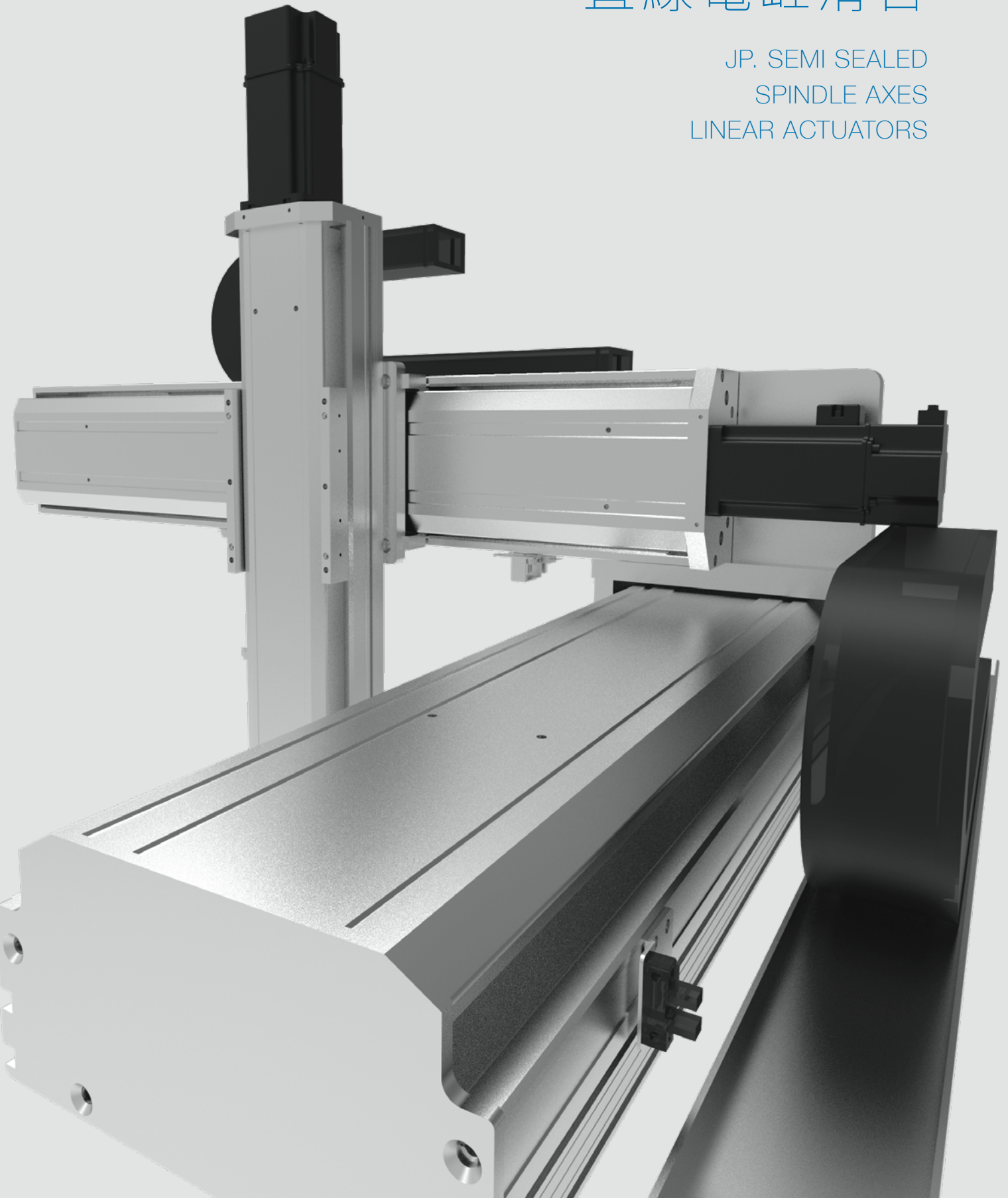

產品結構分析

PRODUCT STRUCTURE

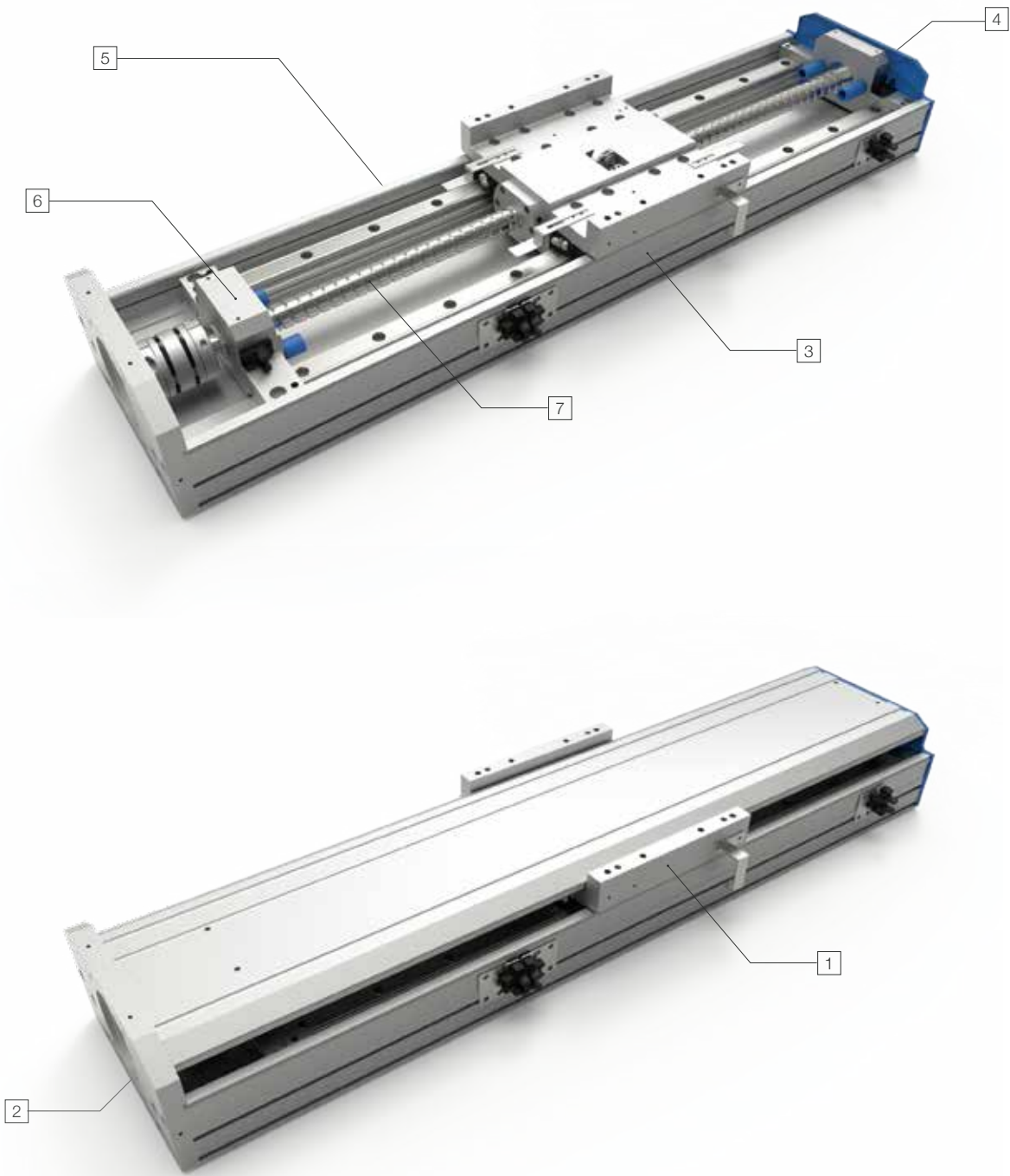

日規電缸滑台 JP linear actuator
歐規電缸滑台 EU linear actuator
超長型電缸滑台 Super length linear actuator
活塞杆電動缸 Cylinder actuator
旋轉台 Rotary stage
精密對位平台 Precision alignment stage
減速機 Gear reducer
十字轉向器 Bevel gearbox
半密螺桿 Semi sealed spindle axis
全密螺桿 Sealed spindle axis
半密同步帶 Semi sealed toothed belt axis
全密同步帶 Sealed toothed belt axis

1 滑動座	3 底座	5 線性滑軌	7 滾珠螺桿
2 馬達板	4 機械檔塊	6 固定座	

以上負載力矩曲線，客戶選用之負載需在我司產品最大負載範圍內 Above load torque curve, the loading should be within the maximum load range

S
28
70
100
134
178
202

產品規格索引

PRODUCT INDEX

日規電缸滑台 JP linear actuator
歐規電缸滑台 EU linear actuator
超長型電缸滑台 Super length linear actuator
活塞杆電動缸 Cylinder actuator
旋轉台 Rotary stage
精密對位平台 Precision alignment stage
減速機 Gear reducer
十字轉向器 Bevel gearbox

半密螺桿 Semi sealed spindle axes
全密螺桿 Sealed spindle axes
半密同步帶 Semi sealed toothed belt axes
全密同步帶 Sealed toothed belt axes

尺寸 Size	滑塊數量 Number of Slides	馬達 Motor Spec		螺桿規格 (C7/C5級) Ball Screw Spec			最高速度 Max Speed (mm/s)	最大負載 Maximum Load (Kg)						
		功率 Motor Power (W)	額定扭矩 Nominal Thrust (N)	重複精度 Rep. Accuracy (mm)	直徑 Screw Diameter (mm)	導程 Pitch (mm)		水平 Horizontal	側掛 Sidehang	垂直 Vertical				
28	1P	28步進	0.09	±0.01 / ±0.005	08	02	40	2	1	0.5				
70	1P	200 / 400	0.64 / 1.27	±0.01 / ±0.005	16	05	250	13	8	6				
						10	500	13	8	6				
						20	1000	10	6	4				
	2P				16	05	250	20	12	8				
						10	500	20	12	8				
						20	1000	15	8	5				
100	1P	200 / 400	0.64 / 1.27	±0.01 / ±0.005	16	05	250	20	10	7				
						10	500	20	10	7				
						20	1000	10	6	4				
	2P				16	05	250	35	18	12				
						10	500	30	15	10				
						20	1000	15	8	5				
134	2P	400	1.27	±0.01 / ±0.005	16	05	250	55	30	15				
						10	500	50	25	10				
						20	1000	20	10	5				
					20	05	250	55	30	15				
						10	500	50	25	10				
						20	1000	25	15	8				
	16				05	250	20	10	5					
					10	500	85	40	20					
					20	1000	30	15	8					
	4P				20	05	250	85	40	20				
						10	500	70	35	15				
						20	1000	40	20	10				
25		05	250	85		40	20							
		10	500	70		35	15							
		20	1000	40		20	10							
178	4P	750	2.39	±0.01 / ±0.005	16	05	250	120	80	50				
						10	500	100	70	40				
						20	1000	40	30	20				
					20	05	250	120	80	50				
						10	500	100	70	40				
						20	1000	70	40	30				
	25				05	250	120	80	50					
					10	500	100	70	40					
					25	1250	70	40	30					
	202				4P	750	2.39	±0.01 / ±0.005	25	05	250	140	100	70
										10	500	120	80	60
										25	1250	75	50	30
32		05	250	140					100	70				
		10	500	120					80	60				
		20	1250	75					60	30				
32	2500	50	40	20										

S

28

70

100

134

178

202

標準行程及電缸最高速度 Stroke (mm) & Maximum Speed (mm/s)																					頁數 Page		
15	20	30	100	200	300	400	500	600	700	800	900	1000	1100	1200	1300	1400	1500	1600	1700	1800	1900	2000	
	30																						1-10
				250					199	161	133	112											1-12
				500					398	322	266	224											
				1000					795	644	532	447											
				250					223	178	146	122	103										
				500					446	357	292	244	206										
				1000					892	714	584	487	412										
				250					198	161	133	112											1-17
				500					397	321	266	223											
				1000					794	643	531	447											
				250					217	174	143	119	101										
				500					435	349	286	239	203										
				1000					869	698	572	478	405										
				250					246	195	158												1-22
				500					493	390	317												
				1000					986	781	633												
				250					217	179	151	129	111	97	85	75							
				500					433	358	302	257	222	194	170	151							
				1000					866	717	603	514	444	387	340	302							
				2000					1732	1434	1206	1029	888	774	681	604							
				250					215	173	142												
				500					430	346	284												
				1000					860	691	567												
				250					236	194	162	138	118	103	90	79	71						
				500					472	388	324	275	236	205	180	159	141						
				1000					945	776	648	550	472	410	359	318	283						
				2000					1890	1552	1297	1100	945	820	719	635	566						
				250					204	165	136												
				500					408	330	272												
				1000					816	659	544												
				250					225	186	156	133	114	99	87	77	69						
				500					451	372	312	265	228	199	175	154	138						
				1000					901	743	624	531	457	398	349	309	275						
				2000					1803	1487	1247	1061	914	795	698	618	551						
				250					234	196	167	144	125	110	97	87	78	70	63	58	53		
				500					467	392	333	287	250	219	194	173	155	140	127	116	106		
				1250					1168	980	834	718	625	549	485	433	388	350	317	289	264		
				250					211	179	153	133	116	102	91	81	73	66	60	55	50		
				500					422	357	306	265	232	205	182	163	146	132	120	110	101		
				1250					1056	893	765	663	580	512	455	407	366	331	301	275	252		
				250					221	189	164	143	126	112	101	90	82	74	68	62			
				500					442	378	328	287	253	225	201	181	164	149	136	124			
				1000					883	757	656	574	506	450	402	362	327	298	272	249			
				1600					1413	1211	1049	918	809	719	644	579	524	476	435	398			

- 日規電缸滑台
JP. linear actuator
- 歐規電缸滑台
EU. linear actuator
- 超長型電缸滑台
Super length linear actuator
- 活塞杆電動缸
Cylinder actuator
- 旋轉台
Rotary stage
- 精密對位平台
Precision alignment stage
- 減速機
Gear reducer
- 十字轉向器
Bevel gearbox

- 半密螺桿
Semi sealed spindle axes
- 全密螺桿
Sealed spindle axes
- 半密同步帶
Semi sealed toothed belt axes
- 全密同步帶
Sealed toothed belt axes

S

- 28
- 70
- 100
- 134
- 178
- 202

產品規格索引

PRODUCT INDEX

日規電缸滑台 JP linear actuator
歐規電缸滑台 EU linear actuator
超長型電缸滑台 Super length linear actuator
活塞杆電動缸 Cylinder actuator
旋轉台 Rotary stage
精密對位平台 Precision alignment stage
減速機 Gear reducer
十字轉向器 Bevel gearbox
半密螺桿 Semi sealed spindle axes
全密螺桿 Sealed spindle axes
半密同步帶 Semi sealed toothed belt axes
全密同步帶 Sealed toothed belt axes

尺寸 Size	滑塊數量 Number of Slides	馬達 Motor Spec		螺桿規格 (C7/C5級) Ball Screw Spec			最高速度 Max Speed (mm/s)	最大負載 Maximum Load (Kg)						
		功率 Motor Power (W)	額定扭矩 Nominal Thrust (N)	重複精度 Rep. Accuracy (mm)	直徑 Screw Diameter (mm)	導程 Pitch (mm)		水平 Horizontal	側掛 Sidehang	垂直 Vertical				
70	1P	200 / 400	0.64 / 1.27	±0.01 / ±0.005	16	05	250	13	8	6				
						10	500	13	8	6				
						20	1000	10	6	4				
	2P				16	05	250	20	12	8				
						10	500	20	12	8				
						20	1000	15	8	5				
100	1P	200 / 400	0.64 / 1.27	±0.01 / ±0.005	16	05	250	20	10	7				
						10	500	20	10	7				
						20	1000	10	6	4				
	2P				16	05	250	35	18	12				
						10	500	30	15	10				
						20	1000	15	8	5				
134	2P	400	1.27	±0.01 / ±0.005	16	05	250	55	30	15				
						10	500	50	25	10				
						20	1000	20	10	5				
					20	05	250	55	30	15				
						10	500	50	25	10				
						20	1000	25	15	8				
	16				40	2000	20	10	5					
					05	250	85	40	20					
						10	500	70	35	15				
	20					20	1000	30	15	8				
					05	250	85	40	20					
					10	500	70	35	15					
20	20	1000	40	20	10									
	40	2000	30	15	8									
	178	4P	750	2.39	±0.01 / ±0.005	16	05	250	120	80	50			
10							500	100	70	40				
20							1000	40	30	20				
20						05	250	120	80	50				
						10	500	100	70	40				
						20	1000	70	40	30				
25	40	2000				40	30	20						
	05	250				120	80	50						
	10	500				100	70	40						
25	25	1250				70	40	30						
	202	4P				750	2.39	±0.01 / ±0.005	25	05	250	140	100	70
										10	500	120	80	60
25			1250	75	50					30				
32	05		250	140	100				70					
	10		500	120	80				60					
	20		1250	75	60				30					
32	32	2500	50	40	20									

S

28

70

100

134

178

202

標準行程及電缸最高速度 Stroke (mm) & Maximum Speed (mm/s)																					頁數 Page			
15	20	30	100	200	300	400	500	600	700	800	900	1000	1100	1200	1300	1400	1500	1600	1700	1800	1900	2000		
					250			246	195	158	131	110											1-12	
					500			492	390	316	262	220												
					1000			984	780	633	524	441												
					250			218	175	144	120	102												
					500			437	350	287	240	203												
					1000			873	701	574	480	406												
					250				202	164	135	113											1-17	
					500				405	327	270	227												
					1000				810	655	540	453												
					250				222	178	146	121	103											
					500				444	355	291	243	206											
					1000				888	711	582	485	411											
					250				238	189	154												1-22	
					500				476	379	308													
					1000				952	757	616													
					250					211	175	147	126	109	95	84	74							
					500					421	350	295	252	218	190	167	148							
					1000					842	699	589	504	435	380	335	297							
					2000					1685	1398	1179	1007	871	760	669	594							
					250				209	169	139												1-27	
					500				418	337	277													
					1000				837	674	555													
					250					230	190	159	135	116	101	88	78	70						
					500					461	379	318	270	232	202	177	157	139						
					1000					922	759	625	540	464	403	354	313	279						
					2000					1844	1517	1271	1079	928	807	708	626	558						
					250					199	161	133											1-30	
					500					397	322	266												
					1000					795	644	532												
					250					220	182	153	130	112	98	86	76	69						
					500					440	364	306	260	225	196	172	152	136						
					1000					880	727	611	521	449	391	344	305	272						
					2000					1760	1455	1222	1042	898	782	688	609	543						
					250					229	192	164	141	123	108	96	85	77	69	63	57	52		
					500					457	384	327	282	246	216	191	171	153	138	125	114	105		
					1250					1143	960	818	706	615	540	479	427	383	346	314	286	262		
					250					210	178	152	132	116	102	91	81	73	66	60	55	50		
					500					420	355	305	264	231	204	181	162	146	132	120	110	100		
					1250					1050	889	762	660	578	510	453	405	365	330	300	274	251		
					250					220	189	163	143	126	112	100	90	82	74	68	62			
					500					440	377	326	286	252	224	200	180	163	148	135	124			
					1000					879	753	653	571	504	448	401	361	326	297	271	248			
					1600					1406	1205	1045	914	807	717	641	577	522	475	433	397			

- 日規電缸滑台
JP linear actuator
- 歐規電缸滑台
EU linear actuator
- 超長型電缸滑台
Super length linear actuator
- 活塞杆電動缸
Cylinder actuator
- 旋轉台
Rotary stage
- 精密對位平台
Precision alignment stage
- 減速機
Gear reducer
- 十字轉向器
Bevel gearbox

- 半密螺桿
Semi sealed spindle axes
- 全密螺桿
Sealed spindle axes
- 半密同步帶
Semi sealed toothed belt axes
- 全密同步帶
Sealed toothed belt axes

S

- 28
- 70
- 100
- 134
- 178
- 202

日規半密式螺桿直線電缸滑台

JP. SEMI SEALED SPINDLE AXES LINEAR ACTUATOR

- 日規電缸滑台
JP linear actuator
- 歐規電缸滑台
EU linear actuator
- 超長型電缸滑台
Super length linear actuator
- 活桿電缸
Cylinder actuator
- 旋轉台
Rotary stage
- 精密對位平台
Precision alignment stage
- 減速機
Gear reducer
- 十字轉向器
Bevel gearbox
- 半密螺桿
Semi sealed spindle axes
- 全密螺桿
Sealed spindle axes
- 半密同步帶
Semi sealed toothed belt axes
- 全密同步帶
Sealed toothed belt axes



產品專利號: 2016211984545 National Patent of China

AIMS-28-15-0802-1P-OL-CM-S28

半密螺桿 Semi Sealed Spindle Axes	缸徑 Size (mm)	行程 Stroke (mm)	規格 Ball Screw Size (mm)	滑塊數量 Number of Slides	鎖位 Assembly Position	馬達安裝位置 Motor Position	馬達功率 Motor Power (W)
直徑 Φ	導程 Pitch	1P 1個 1 Slide	OL 外鎖 Outside	CM 直接安裝 Direct	S 步進馬達 Stepper Motor		S28
08	02						

● 有選項 Optional ● 無選項 No options

馬達輸出 Motor Power (W)	28步進		滑塊數量 Number of Slides	1P	
額定扭矩 Torque (Nm)	0.09		力和力矩 Force and torques	F_y (N)	12
螺桿等級 Ball Screw Level	C7轉造 Rolled Ball Screw			F_z (N)	24
重複定位精度 Rep. Accuracy (mm)	±0.01			M_x (N.m)	0.3
螺桿規格 Ball Screw Size (mm)	Ø08	02		M_y (N.m)	0.1
額定推力 Nominal Thrust (N)	220			M_z (N.m)	0.1
最高速度 Max. Speed (mm/s)	40			面積二次矩 2nd moment of area	L_{xx} (cm ⁴)
行程範圍 Stroke Range (mm)	15/20/30		L_{yy} (cm ⁴)	-	
最大負載值 Max. Load (Kg)	水平 Horizontal	2	0mm行程基本重量 Basic Weight for 0mm Stroke (kg)		0.64
	側掛 Sidehang	1	每100mm行程增加重量 Additional Weight per 100mm Stroke (kg)		0.075
	垂直 Vertical	0.5			

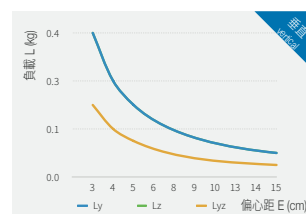
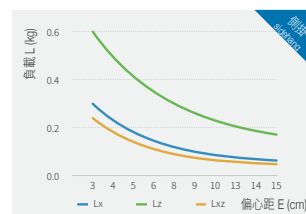
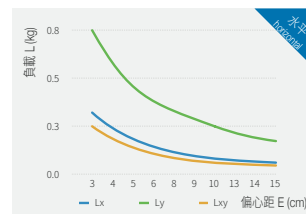

以上負載力矩曲線，客戶選用之負載需在我司產品最大負載範圍內 Above load torque curve, the loading should be within the maximum load range

AIMS28-1P-CM 直接安裝 motor direct installed

單位 Unit: mm

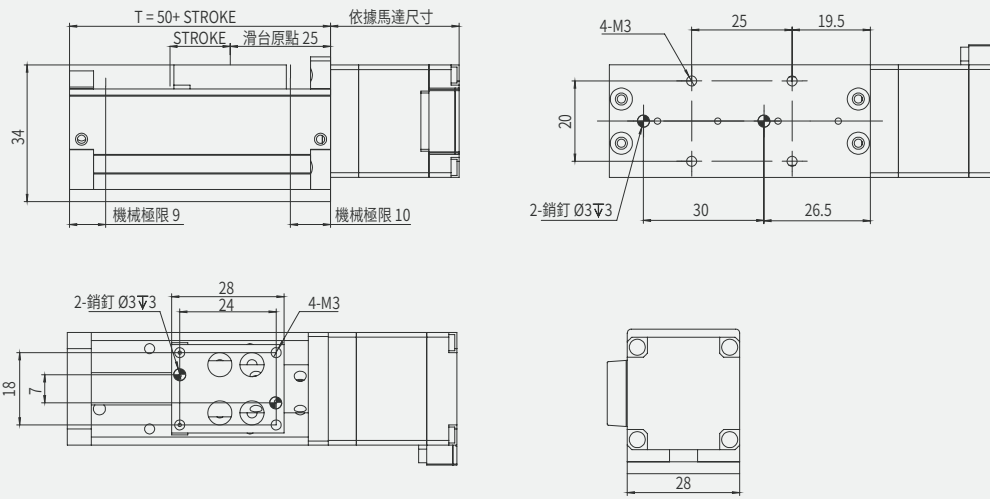

行程 Stroke	15	20	30
T	65	70	80
重量 Weight (Kg)	0.12	0.14	0.16

本圖面僅供參考用途，實際尺寸皆以實際提供之2D/3D圖紙為準 This drawing is for reference only. The actual dimensions are based on the actual 2D / 3D drawings provided.

- 日規電缸滑台
J linear actuator
- 歐規電缸滑台
EU linear actuator
- 超長型電缸滑台
Super length linear actuator
- 活塞杆電動缸
Cylinder actuator
- 旋轉台
Rotary stage
- 精密對位平台
Precision alignment stage
- 減速機
Gear reducer
- 十字轉向器
Bevel gearbox
- 半密螺桿
Semi sealed spindle axes
- 全密螺桿
Sealed spindle axes
- 半密同步帶
Semi sealed toothed belt axes
- 全密同步帶
Sealed toothed belt axes

S

28

70

100

134

178

202

日規半密式螺桿直線電缸滑台

JP. SEMI SEALED SPINDLE AXES LINEAR ACTUATOR

- 日規電缸滑台
JP linear actuator
- 歐規電缸滑台
EU linear actuator
- 超長型電缸滑台
Super length linear actuator
- 活桿電缸
Cylinder actuator
- 旋轉台
Rotary stage
- 精密對位平台
Precision alignment stage
- 減速機
Gear reducer
- 十字轉向器
Bevel gearbox
- 半密螺桿
Semi sealed spindle axes
- 全密螺桿
Sealed spindle axes
- 半密同步帶
Semi sealed toothed belt axes
- 全密同步帶
Sealed toothed belt axes



產品專利號: 2016211984545 National Patent of China

AIMS - 70 - 400 - 1610 - 1P - OL - CM - M200 - O - S3

半密螺桿 Semi Sealed Spindle Axes	缸徑 Size (mm)	行程 Stroke (mm)	規格 Ball Screw Size (mm)	滑塊數量 Number of Slides	鎖位 Assembly Position	馬達安裝位置 Motor Position	馬達功率 Motor Power (W)	光電開關 Optical Proximity Sensor Position	開關數 Number of Sensors	
	直徑 ϕ	導程 Pitch		1P 1個 1 Slide	OL 外鎖 Outside	CM 直接安裝 Direct	M 三菱 Mitsubishi	T 台達 Delta	無 None	S3 3個開關 3x Sensors
		05		2P 2個 2 Slides	IL 內鎖 Inside	DM 下側間接 Downside Parallel	P 松下 Panasonic	O 其他 Others	O 外掛 Hang Outside	Sn n個開關 rx Sensors
	16	10				LM 左側間接 Leftside Parallel	Y 安川 Yokawa			
		20				RM 右側間接 Rightside Parallel	200 / 400			

● 有選項 Optional ● 無選項 No options

馬達輸出 Motor Power (W)	200 / 400					
額定扭矩 Torque (Nm)	0.64 / 1.27					
螺桿等級 Ball Screw Level	C7轉造 / C5研磨 C7 Rolled Ball Screw / C5 Ground Ball Screw					
重複定位精度 Rep. Accuracy (mm)	$\pm 0.01 / \pm 0.005$					
螺桿規格 Ball Screw Size (mm)	$\phi 16$	05	10	20		
額定推力 Nominal Thrust (N)	200 (W)	680	340	170		
	400 (W)	1360	680	340		
最高速度 Max. Speed (mm/s)	250 500 1000					
行程範圍 Stroke Range (mm)	100...1000 / 50 間隔 Pitch					
最大負載值 Max. Load (kg)	水平 Horizontal	1P	13	13	10	15
	側掛 Sidehang	1P	8	8	6	8
		2P	12	12	8	8
垂直 Vertical	1P	6	6	4	5	
		2P	8	8	8	5

滑塊數量 Number of Slides	1P	2P
力和力矩 Force and torques	F_y (N)	80 120
	F_z (N)	180 280
	M_x (N.m)	12 20
	M_y (N.m)	5 10
面積二次矩 2nd moment of area	M_z (N.m)	5 10
	L_{xx} (cm ²)	2.9
	L_{yy} (cm ²)	41
0mm行程基本重量 Basic Weight for 0mm Stroke (kg)	3.7	
每100mm行程增加重量 Additional Weight per 100mm Stroke (kg)	0.8	
光電開關 Optical Proximity Sensor	SUX-PM-L45	

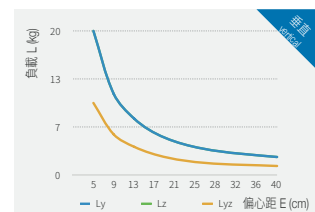
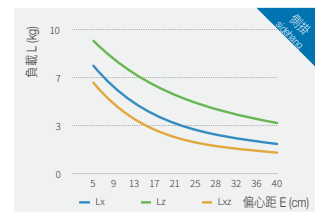
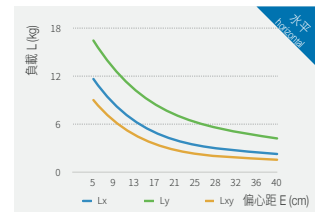

以上負載力矩曲線，客戶選用之負載需在我司產品最大負載範圍內 Above load torque curve, the loading should be within the maximum load range

AIMS70-1P-CM 直接安裝 motor direct installed

單位 Unit: mm

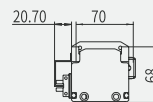
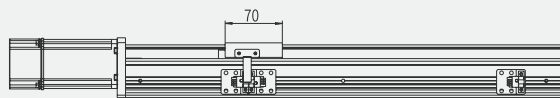
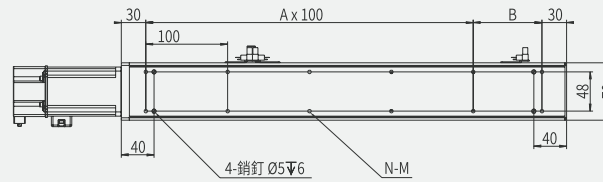
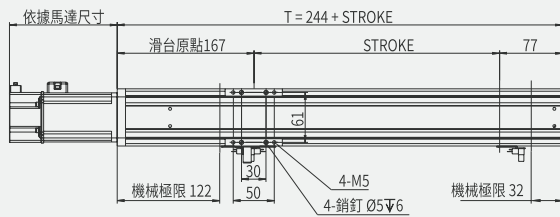

鎖位方式 Screw Position	M
外鎖 Outside	M5
內鎖 Inside	Φ5.5

行程 Stroke	100	150	200	250	300	350	400	500	600	700
T	344	394	444	494	544	594	644	744	844	944
B	84	34	84	34	84	34	84	84	84	84
A	2	3	3	4	4	5	5	6	7	8
N	8	10	10	12	12	14	14	16	18	20
重量 Weight (Kg)	4.5	4.9	5.3	5.7	6.1	6.5	6.9	7.7	8.5	9.3

本圖面僅供參考用途, 實際尺寸皆以實際提供之2D/3D圖紙為準 This drawing is for reference only. The actual dimensions are based on the actual 2D / 3D drawings provided.

AIMS70-2P-CM 直接安裝 motor direct installed

單位 Unit: mm

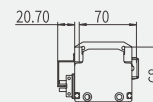
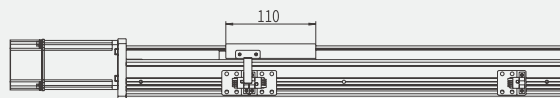
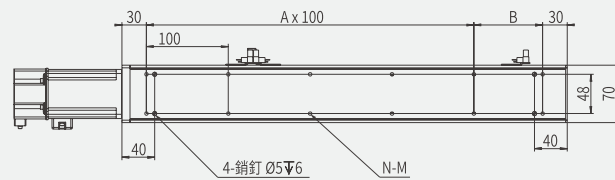
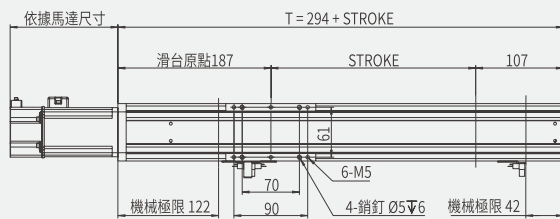

鎖位方式 Screw Position	M
外鎖 Outside	M5
內鎖 Inside	Φ5.5

行程 Stroke	100	150	200	250	300	350	400	500	600	700	800
T	394	444	494	544	594	644	694	794	894	994	1094
B	34	84	34	84	34	84	34	34	34	34	34
A	3	3	4	4	5	5	6	7	8	9	10
N	10	10	12	12	14	14	16	18	20	22	24
重量 Weight (Kg)	4.9	5.3	5.7	6.1	6.5	6.9	7.7	8.5	9.3	10.1	10.9

本圖面僅供參考用途, 實際尺寸皆以實際提供之2D/3D圖紙為準 This drawing is for reference only. The actual dimensions are based on the actual 2D / 3D drawings provided.

 日規電缸滑台
J linear actuator

 歐規電缸滑台
EU linear actuator

 超長型電缸滑台
Super length linear actuator

 活塞杆電動缸
Cylinder actuator

 旋轉台
Rotary stage

 精密對位平台
Precision alignment stage

 減速機
Gear reducer

 十字轉向器
Bevel gearbox

 半密螺桿
Semi sealed spindle axis

 全密螺桿
Sealed spindle axis

 半密同步帶
Semi sealed toothed belt axis

 全密同步帶
Sealed toothed belt axis

S

28

70

100

134

178

202

日規電缸滑台
JP linear actuator

歐規電缸滑台
EU linear actuator

超長型電缸滑台
Super length linear actuator

活塞缸電動缸
Cylinder actuator

旋轉台
Rotary stage

精密對位平台
Precision alignment stage

減速機
Gear reducer

十字轉向器
Bevel gearbox

半密螺桿
Semi sealed spindle axes

全密螺桿
Sealed spindle axes

半密同步帶
Semi sealed toothed belt axes

全密同步帶
Sealed toothed belt axes

AIMS70-1P-LM 馬達左側間接安裝 motor leftside parallel installed

單位 Unit: mm

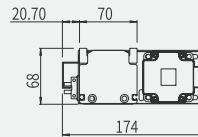
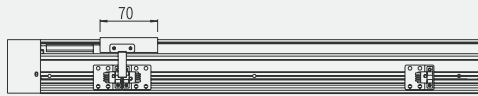
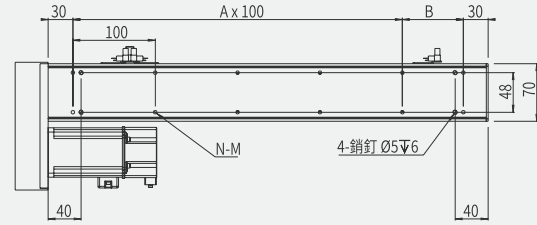
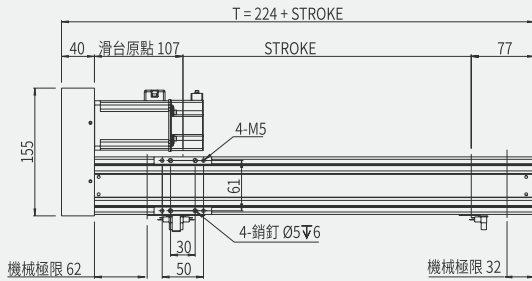

鎖位方式 Screw Method	M
外鎖 Exterior	M5
內鎖 Interior	Φ5.5

行程 Stroke	100	150	200	250	300	350	400	500	600	700
T	324	374	424	474	524	574	624	724	824	924
B	24	74	24	74	24	74	24	24	24	24
A	2	2	3	3	4	4	5	6	7	8
N	8	8	10	10	12	12	14	16	18	20
重量 Weight (Kg)	5	5.4	5.8	6.2	6.6	7	7.4	8.2	9	9.8

本圖面僅供參考用途，實際尺寸皆以實際提供之2D/3D圖紙為準 This drawing is for reference only. The actual dimensions are based on the actual 2D / 3D drawings provided.

AIMS70-2P-LM 馬達左側間接安裝 motor leftside parallel installed

單位 Unit: mm

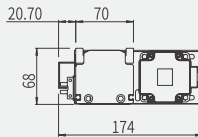
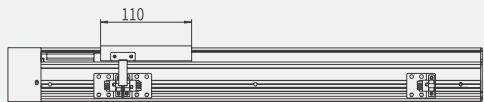
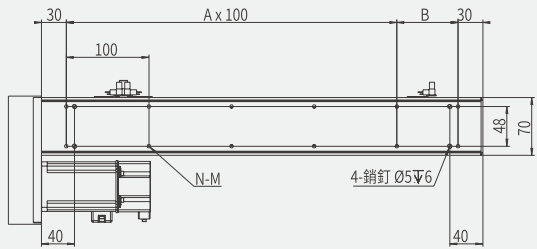
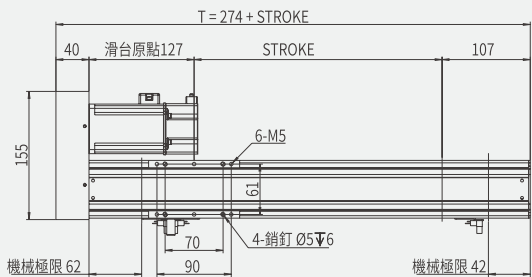

鎖位方式 Screw Method	M
外鎖 Exterior	M5
內鎖 Interior	Φ5.5

行程 Stroke	100	150	200	250	300	350	400	500	600	700	800
T	374	424	474	524	574	624	674	774	874	974	1074
B	74	24	74	24	74	24	74	74	74	74	74
A	2	3	3	4	4	5	5	6	7	8	9
N	8	10	10	12	12	14	14	16	18	20	22
重量 Weight (Kg)	5.4	5.8	6.2	6.6	7	7.4	7.8	8.8	9.8	10.8	11.8

本圖面僅供參考用途，實際尺寸皆以實際提供之2D/3D圖紙為準 This drawing is for reference only. The actual dimensions are based on the actual 2D / 3D drawings provided.

S

28

70

100

134

178

202

AIMS70-1P-RM 向右間接安裝 motor rightside parallel installed

單位 Unit: mm

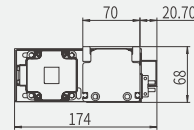
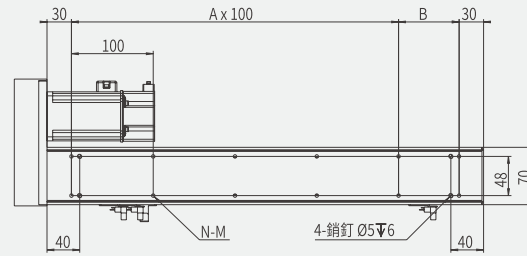
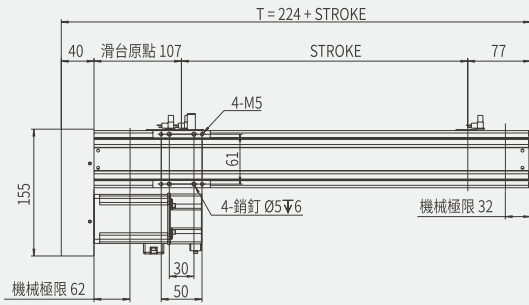

鎖位方式 Screw Method	M
外鎖 Exterior	M5
內鎖 Interior	Φ5.5

行程 Stroke	100	150	200	250	300	350	400	500	600	700
T	324	374	424	474	524	574	624	724	824	924
B	24	74	24	74	24	74	24	24	24	24
A	2	2	3	3	4	4	5	6	7	8
N	8	8	10	10	12	12	14	16	18	20
重量 Weight (Kg)	5	5.4	5.8	6.2	6.6	7	7.4	8.2	9	9.8

本圖面僅供參考用途，實際尺寸皆以實際提供之2D/3D圖紙為準 This drawing is for reference only. The actual dimensions are based on the actual 2D / 3D drawings provided.

AIMS70-2P-RM 向右間接安裝 motor rightside parallel installed

單位 Unit: mm

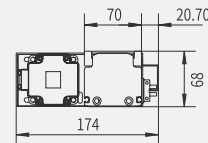
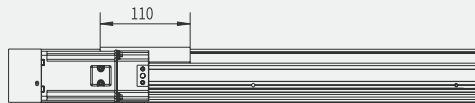
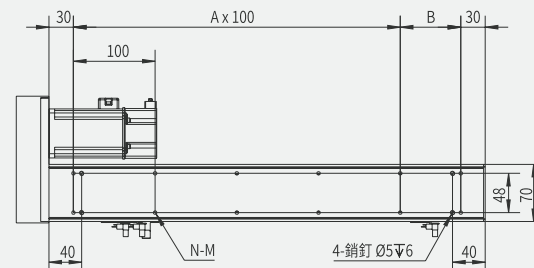
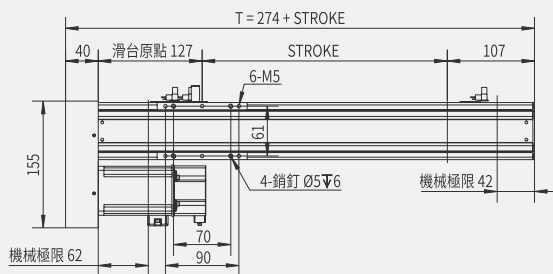

鎖位方式 Screw Method	M
外鎖 Exterior	M5
內鎖 Interior	Φ5.5

行程 Stroke	100	150	200	250	300	350	400	500	600	700	800
T	374	424	474	524	574	624	674	774	874	974	1074
B	74	24	74	24	74	24	74	74	74	74	74
A	2	3	3	4	4	5	5	6	7	8	9
N	8	10	10	12	12	14	14	16	18	20	22
重量 Weight (Kg)	5.4	5.8	6.2	6.6	7	7.4	7.8	8.8	9.8	10.8	11.8

本圖面僅供參考用途，實際尺寸皆以實際提供之2D/3D圖紙為準 This drawing is for reference only. The actual dimensions are based on the actual 2D / 3D drawings provided.

 日規電缸滑台
J linear actuator

 歐規電缸滑台
EU linear actuator

 超長型電缸滑台
Super length linear actuator

 活塞杆電動缸
Cylinder actuator

 旋轉台
Rotary stage

 精密對位平台
Precision alignment stage

 減速機
Gear reducer

 十字轉向器
Bevel gearbox

 半密螺桿
Semi sealed spindle axis

 全密螺桿
Sealed spindle axis

 半密同步帶
Semi sealed toothed belt axis

 全密同步帶
Sealed toothed belt axis

S

28

70

100

134

178

202

- 日規電缸滑台
JP linear actuator
- 歐規電缸滑台
EU linear actuator
- 超長型電缸滑台
Super length linear actuator
- 活桿電缸
Cylinder actuator
- 旋轉台
Rotary stage
- 精密對位平台
Precision alignment stage
- 減速機
Gear reducer
- 十字轉向器
Bevel gearbox
- 半密螺桿
Semi sealed spindle axes
- 全密螺桿
Sealed spindle axes
- 半密同步帶
Semi sealed toothed belt axes
- 全密同步帶
Sealed toothed belt axes

AIMS70-1P-DM 馬達下側間接安裝 motor downside parallel installed

單位 Unit: mm

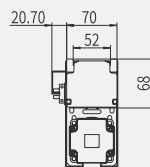
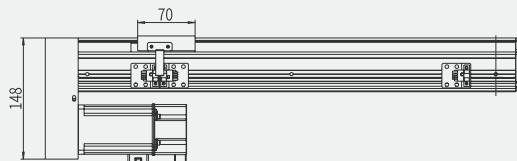
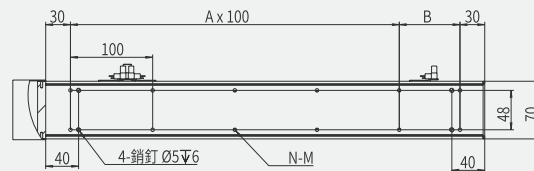
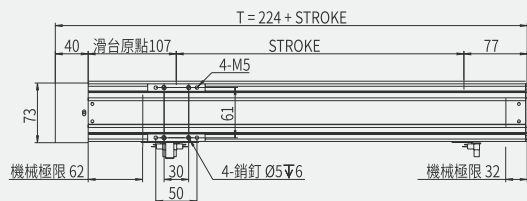

鎖位方式 Screw Method	M
外鎖 Exterior	M5
內鎖 Interior	Φ5.5

行程 Stroke	100	150	200	250	300	350	400	500	600	700
T	324	374	424	474	524	574	624	724	824	924
B	24	74	24	74	24	74	24	24	24	24
A	2	2	3	3	4	4	5	6	7	8
N	8	8	10	10	12	12	14	16	18	20
重量 Weight (Kg)	5	5.4	5.8	6.2	6.6	7	7.4	8.2	9	9.8

本圖面僅供參考用途，實際尺寸皆以實際提供之2D/3D圖紙為準 This drawing is for reference only. The actual dimensions are based on the actual 2D / 3D drawings provided.

AIMS70-2P-DM 馬達下側間接安裝 motor downside parallel installed

單位 Unit: mm

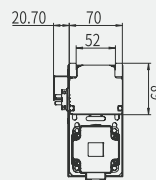
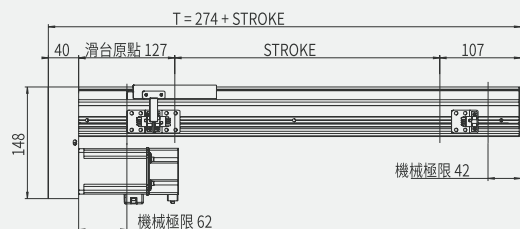
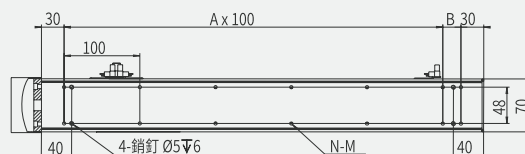
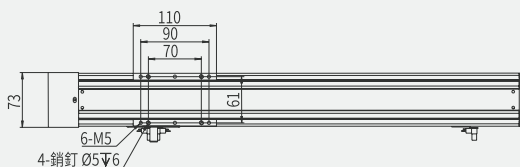

鎖位方式 Screw Method	M
外鎖 Exterior	M5
內鎖 Interior	Φ5.5

行程 Stroke	100	150	200	250	300	350	400	500	600	700	800
T	374	424	474	524	574	624	674	774	874	974	1074
B	74	24	74	24	74	24	74	74	74	74	74
A	2	3	3	4	4	5	5	6	7	8	9
N	8	10	10	12	12	14	14	16	18	20	22
重量 Weight (Kg)	5.4	5.8	6.2	6.6	7	7.4	7.8	8.8	9.8	10.8	11.8

本圖面僅供參考用途，實際尺寸皆以實際提供之2D/3D圖紙為準 This drawing is for reference only. The actual dimensions are based on the actual 2D / 3D drawings provided.

S

28

70

100

134

178

202

日規半密式螺桿直線電缸滑台



JP. SEMI SEALED SPINDLE AXES LINEAR ACTUATOR



產品專利號: 2016211984545 National Patent of China

AIMS-100-400-1610-LG1-1P-OL-CM-M400-O-S3-OIL

半密螺桿 Semi Sealed Spindle Axes	缸徑 Size (mm)	行程 Stroke (mm)	規格 Ball Screw Size (mm)	導軌 Guide Type	滑塊數量 Number of Slides	鎖位 Assembly Position	馬達安裝位置 Motor Position	馬達功率 Motor Power (W)	光電開關 Optical Proximity Sensor Position	開關數 Number of Sensors	自動給油 Auto Lubrication
	16	05 10 20		LG1 高軌 High Guide LG2 寬軌 Wide Guide	1P 1個 1 Side 2P 2個 2 Slides	OL 外鎖 Outside IL 內鎖 Inside	CM 直接安裝 Direct DM 下側間接 Downside Parallel LM 左側間接 Leftside Parallel RM 右側間接 Rightside Parallel	M 三菱 Mitsubishi T 台達 Delta P 松下 Panasonic O 其他 Others Y 安川 Yaskawa 200 / 400	無 None O 外掛 Hang Outside I 內藏 Hide Inside	S3 3個開關 3x Sensors Sn n個開關 nx Sensors	

● 有選項 Optional ● 無選項 No options

馬達輸出 Motor Power (W)	200 / 400						
額定扭矩 Torque (Nm)	0.64 / 1.27						
螺桿等級 Ball Screw Level	C7轉造 / C5研磨 C7 Rolled Ball Screw / C5 Ground Ball Screw						
重複定位精度 Rep. Accuracy (mm)	±0.01 / ±0.005						
螺桿規格 Ball Screw Size (mm)	Ø16	05	10	16	20		
額定推力 Nominal Thrust (N)	200 (W)	680	340	210	170		
	400 (W)	1360	680	420	340		
最高速度 Max. Speed (mm/s)	250 500 800 1000						
行程範圍 Stroke Range (mm)	100...1000 / 50 間隔 Pitch						
最大負載值 Max. Load (kg)	水平 Horizontal	1P	20	20	13	10	15
	側掛 Sidehang	1P	10	10	7	6	
		2P	18	15	10	8	
垂直 Vertical	1P	7	7	5	4		
	2P	12	10	8	5		

滑塊數量 Number of Slides	1P	2P
力和力矩 Force and torques	F _y (N)	450 700
	F _z (N)	850 1300
	M _x (N.m)	41 53
	M _y (N.m)	35
面積二次矩 2nd moment of area	M _z (N.m)	35
	L _{xx} (cm ²)	21.9
面積二次矩 2nd moment of area	L _{yy} (cm ²)	193
	0mm行程基本重量 Basic Weight for 0mm Stroke (kg)	5.5
每100mm行程增加重量 Additional Weight per 100mm Stroke (kg)	1	
光電開關 Optical Proximity Sensor	SUX-PM-L45	

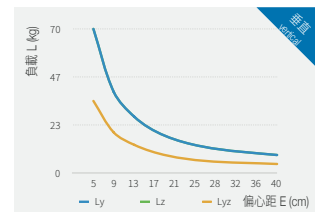
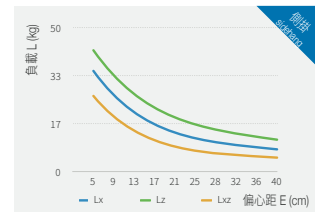
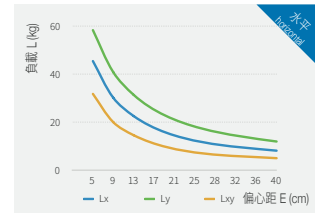

以上負載力矩曲線，客戶選用之負載需在我司產品最大負載範圍內 Above load torque curve, the loading should be within the maximum load range

- 日規電缸滑台
JP linear actuator
- 歐規電缸滑台
EU linear actuator
- 超長型電缸滑台
Super length linear actuator
- 活塞杆電動缸
Cylinder actuator
- 旋轉台
Rotary stage
- 精密對位平台
Precision alignment stage
- 減速機
Gear reducer
- 十字轉向器
Bevel gearbox
- 半密螺桿
Semi sealed spindle axes
- 全密螺桿
Sealed spindle axes
- 半密同步帶
Semi sealed toothed belt axes
- 全密同步帶
Sealed toothed belt axes

S

- 28
- 70
- 100
- 134
- 178
- 202

- 日規電缸滑台
JP linear actuator
- 歐規電缸滑台
EU linear actuator
- 超長型電缸滑台
Super length linear actuator
- 活桿電缸
Cylinder actuator
- 旋轉台
Rotary stage
- 精密對位平台
Precision alignment stage
- 減速機
Gear reducer
- 十字轉向器
Bevel gearbox
- 半密螺桿
Semi sealed spindle axes
- 全密螺桿
Sealed spindle axes
- 半密同步帶
Semi sealed toothed belt axes
- 全密同步帶
Sealed toothed belt axes

AIMS100-1P-CM 直接安裝 motor direct installed

單位 Unit: mm

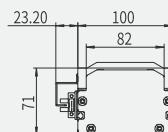
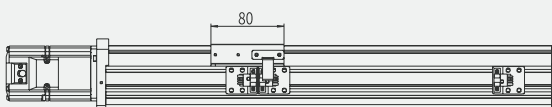
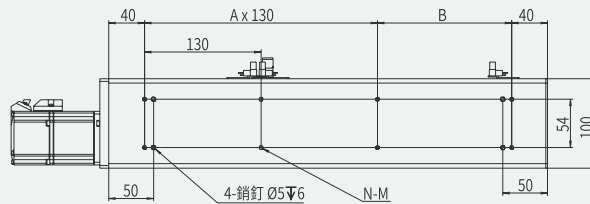
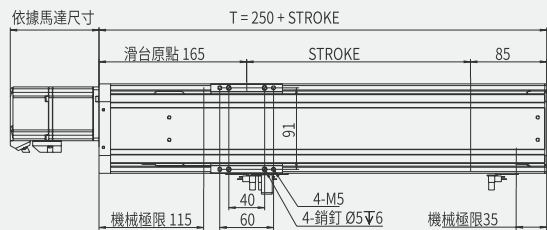

鎖位方式 Screw Method	M
外鎖 Exterior	M5
內鎖 Interior	Φ5.5

行程 Stroke	100	150	200	250	300	350	400	500	600	700	800
T	350	400	450	500	550	600	650	750	850	950	1050
B	130	50	100	150	70	120	40	140	110	80	50
A	1	2	2	2	3	3	4	4	5	6	7
N	6	8	8	8	10	10	12	12	14	16	18
重量 Weight (Kg)	5.5	6	6.5	7	7.5	8	8.5	9.5	10.5	11.5	12.5

本圖面僅供參考用途，實際尺寸皆以實際提供之2D/3D圖紙為準 This drawing is for reference only. The actual dimensions are based on the actual 2D / 3D drawings provided.

AIMS100-2P-CM 直接安裝 motor direct installed

單位 Unit: mm

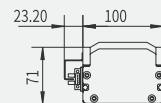
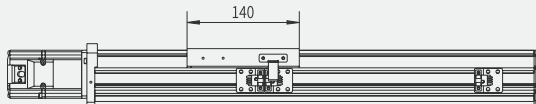
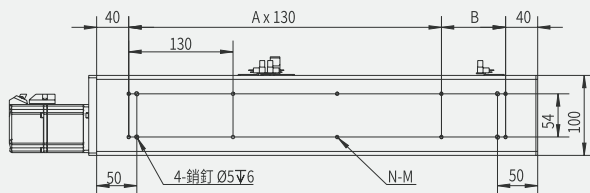
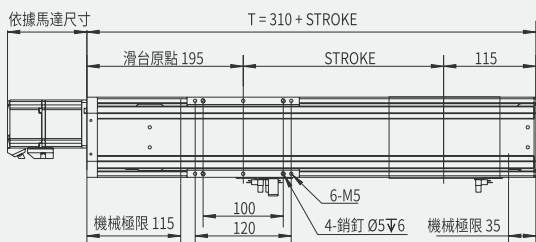

鎖位方式 Screw Method	M
外鎖 Exterior	M5
內鎖 Interior	Φ5.5

行程 Stroke	100	150	200	250	300	350	400	500	600	700	800
T	410	460	510	560	610	660	710	810	910	1010	1110
B	60	110	160	80	130	50	100	70	40	140	110
A	2	2	2	3	3	4	4	5	6	6	7
N	8	8	8	10	10	12	12	14	16	16	18
重量 Weight (Kg)	6.5	7	7.5	8	8.5	9	9.5	10.5	11.5	12.5	13.5

本圖面僅供參考用途，實際尺寸皆以實際提供之2D/3D圖紙為準 This drawing is for reference only. The actual dimensions are based on the actual 2D / 3D drawings provided.

S

28

70

100

134

178

202

AIMS100-1P-LM 馬達左側間接安裝 motor leftside parallel installed

單位 Unit: mm

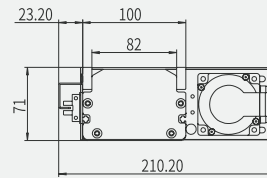
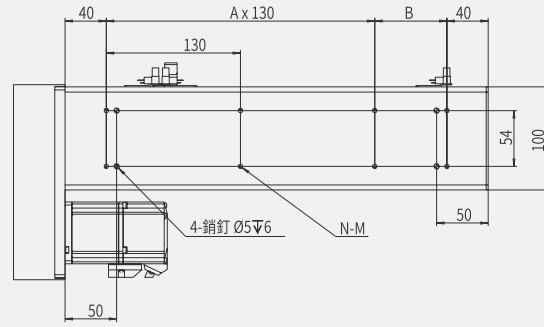
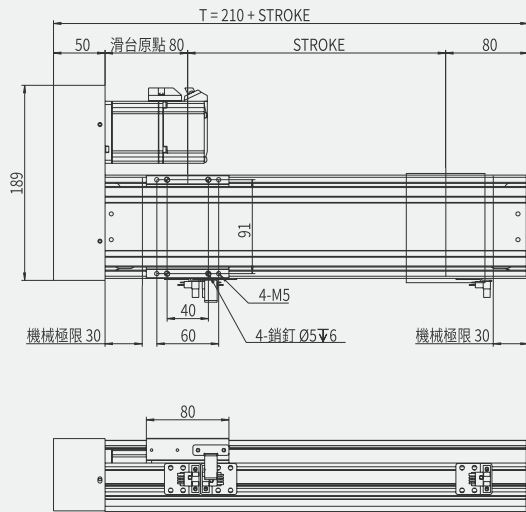

鎖位方式 Screw Method	M
外鎖 Exterior	M5
內鎖 Interior	Φ5.5

行程 Stroke	100	150	200	250	300	350	400	500	600	700	800
T	310	360	410	460	510	560	610	710	810	910	1010
B	50	100	150	70	120	40	90	60	30	130	100
A	1	1	1	2	2	3	3	4	5	5	6
N	6	6	6	8	8	10	10	12	14	14	16
重量 Weight (Kg)	6	6.5	7	7.5	8	8.5	9	10	11	12	13

本圖面僅供參考用途，實際尺寸皆以實際提供之2D/3D圖紙為準 This drawing is for reference only. The actual dimensions are based on the actual 2D / 3D drawings provided.

AIMS100-2P-LM 馬達左側間接安裝 motor leftside parallel installed

單位 Unit: mm

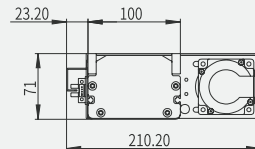
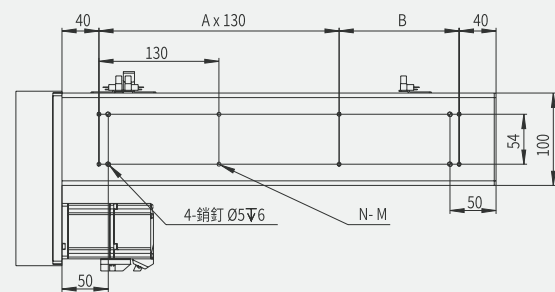
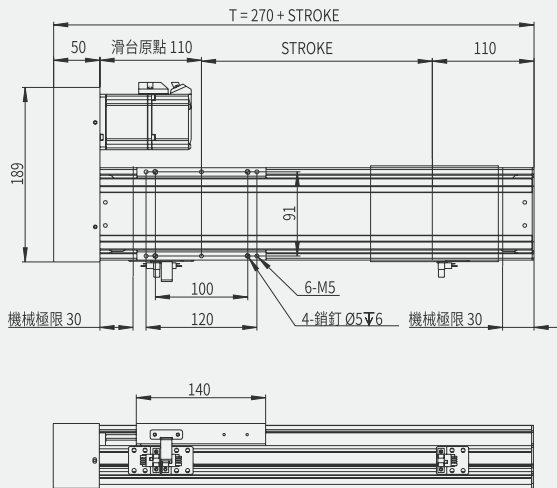

鎖位方式 Screw Method	M
外鎖 Exterior	M5
內鎖 Interior	Φ5.5

行程 Stroke	100	150	200	250	300	350	400	500	600	700	800
T	370	420	470	520	570	620	670	770	870	970	1070
B	110	30	80	130	50	100	150	120	90	60	30
A	1	2	2	2	3	3	3	4	5	6	7
N	6	8	8	8	10	10	10	12	14	16	18
重量 Weight (Kg)	7	7.5	8	8.5	9	9.5	10	11	12	13	14

本圖面僅供參考用途，實際尺寸皆以實際提供之2D/3D圖紙為準 This drawing is for reference only. The actual dimensions are based on the actual 2D / 3D drawings provided.

 日規電缸滑台
J linear actuator

 歐規電缸滑台
EU linear actuator

 超長型電缸滑台
Super length linear actuator

 活塞杆電動缸
Cylinder actuator

 旋轉台
Rotary stage

 精密對位平台
Precision alignment stage

 減速機
Gear reducer

 十字轉向器
Bevel gearbox

 半密螺桿
Semi sealed spindle axis

 全密螺桿
Sealed spindle axis

 半密同步帶
Semi sealed toothed belt axis

 全密同步帶
Sealed toothed belt axis

S

28

70

100

134

178

202

日規電缸滑台
JP linear actuator

歐規電缸滑台
EU linear actuator

超長型電缸滑台
Super length linear actuator

活塞杆電動缸
Cylinder actuator

旋轉台
Rotary stage

精密對位平台
Precision alignment stage

減速機
Gear reducer

十字轉向器
Bevel gearbox

半密螺桿
Semi sealed spindle axes

全密螺桿
Sealed spindle axes

半密同步帶
Semi sealed toothed belt axes

全密同步帶
Sealed toothed belt axes

AIMS100-1P-RM 向右間接安裝 motor rightside parallel installed

單位 Unit: mm

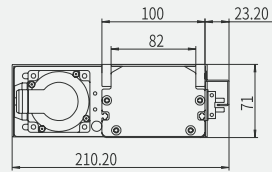
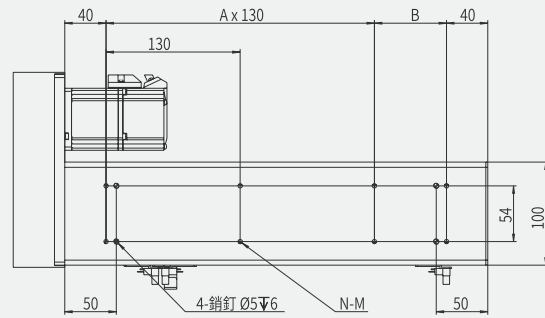
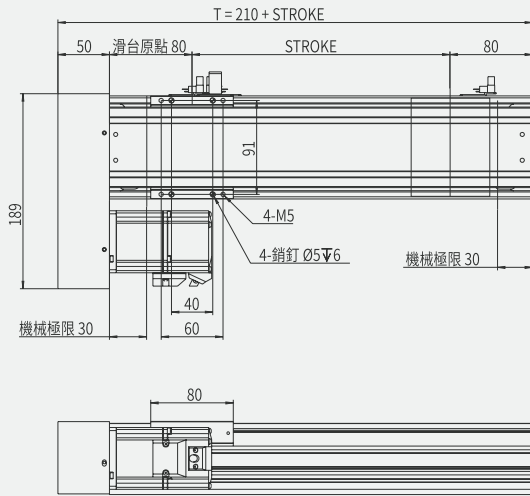

鎖位方式 Screw Method	M
外鎖 Exterior	M5
內鎖 Interior	Φ5.5

行程 Stroke	100	150	200	250	300	350	400	500	600	700	800
T	310	360	410	460	510	560	610	710	810	910	1010
B	50	100	150	70	120	40	90	60	30	130	100
A	1	1	1	2	2	3	3	4	5	5	6
N	6	6	6	8	8	10	10	12	14	14	16
重量 Weight (Kg)	6	6.5	7	7.5	8	8.5	9	10	11	12	13

本圖面僅供參考用途，實際尺寸皆以實際提供之2D/3D圖紙為準 This drawing is for reference only. The actual dimensions are based on the actual 2D / 3D drawings provided.

AIMS100-2P-RM 向右間接安裝 motor rightside parallel installed

單位 Unit: mm

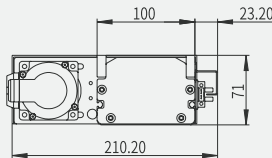
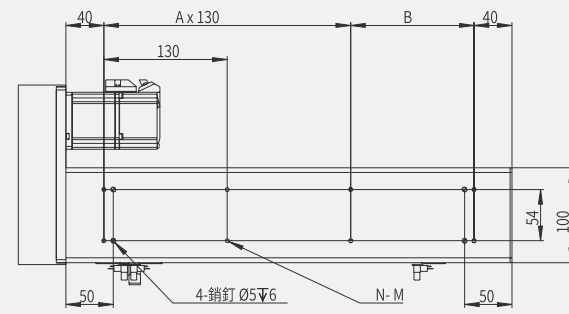
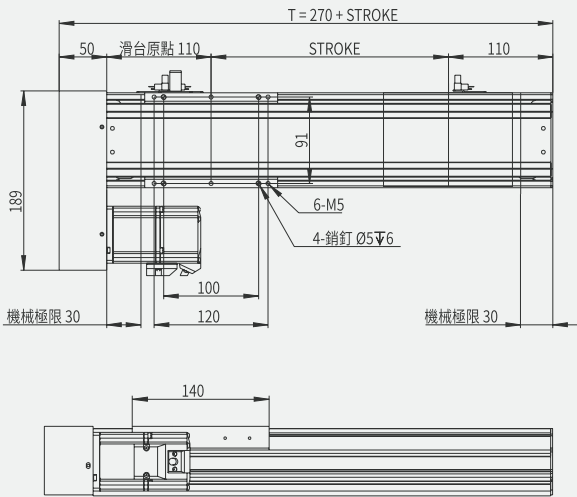

鎖位方式 Screw Method	M
外鎖 Exterior	M5
內鎖 Interior	Φ5.5

行程 Stroke	100	150	200	250	300	350	400	500	600	700	800
T	370	420	470	520	570	620	670	770	870	970	1070
B	110	30	80	130	50	100	150	120	90	60	30
A	1	2	2	2	3	3	3	4	5	6	7
N	6	8	8	8	10	10	10	12	14	16	18
重量 Weight (Kg)	7	7.5	8	8.5	9	9.5	10	11	12	13	14

本圖面僅供參考用途，實際尺寸皆以實際提供之2D/3D圖紙為準 This drawing is for reference only. The actual dimensions are based on the actual 2D / 3D drawings provided.

S

28

70

100

134

178

202

AIMS100-1P-DM 馬達下側間接安裝 motor downside parallel installed

單位 Unit: mm

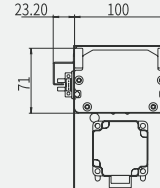
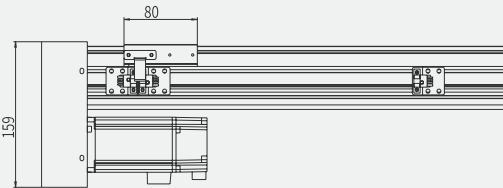
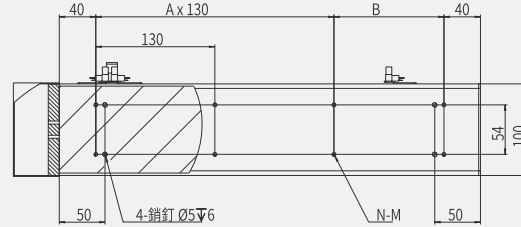
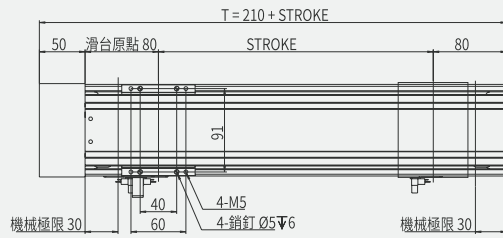

鎖位方式 Screw Method	M
外鎖 Exterior	M5
內鎖 Interior	Φ5.5

行程 Stroke	100	150	200	250	300	350	400	500	600	700	800
T	310	360	410	460	510	560	610	710	810	910	1010
B	50	100	150	70	120	40	90	60	30	130	100
A	1	1	1	2	2	3	3	4	5	5	6
N	6	6	6	8	8	10	10	12	14	14	16
重量 Weight (Kg)	6	6.5	7	7.5	8	8.5	9	10	11	12	13

本圖面僅供參考用途，實際尺寸皆以實際提供之2D/3D圖紙為準 This drawing is for reference only. The actual dimensions are based on the actual 2D / 3D drawings provided.

AIMS100-2P-DM 馬達下側間接安裝 motor downside parallel installed

單位 Unit: mm

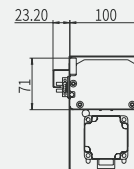
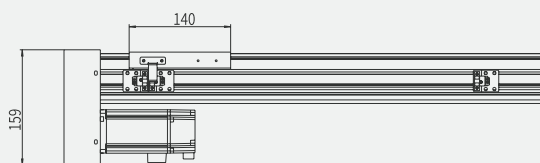
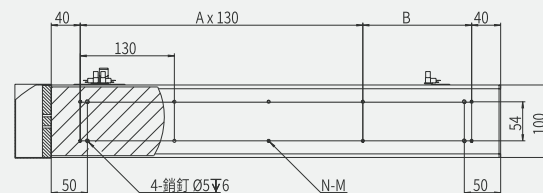
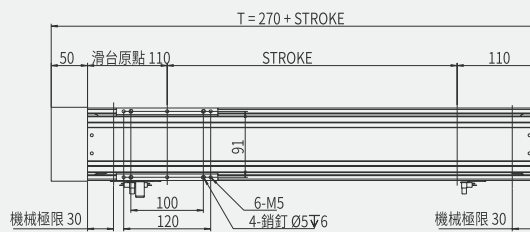

鎖位方式 Screw Method	M
外鎖 Exterior	M5
內鎖 Interior	Φ5.5

行程 Stroke	100	150	200	250	300	350	400	500	600	700	800
T	370	420	470	520	570	620	670	770	870	970	1070
B	110	30	80	130	50	100	150	120	90	60	30
A	1	2	2	2	3	3	3	4	5	6	7
N	6	8	8	8	10	10	10	12	14	16	18
重量 Weight (Kg)	7	7.5	8	8.5	9	9.5	10	11	12	13	14

本圖面僅供參考用途，實際尺寸皆以實際提供之2D/3D圖紙為準 This drawing is for reference only. The actual dimensions are based on the actual 2D / 3D drawings provided.

- 日規電缸滑台
Linear actuator
- 歐規電缸滑台
EU linear actuator
- 超長型電缸滑台
Super length linear actuator
- 活塞杆電動缸
Cylinder actuator
- 旋轉台
Rotary stage
- 精密對位平台
Precision alignment stage
- 減速機
Gear reducer
- 十字轉向器
Bevel gearbox

- 半密螺桿
Semi sealed spindle axis
- 全密螺桿
Sealed spindle axis
- 半密同步帶
Semi sealed toothed belt axes
- 全密同步帶
Sealed toothed belt axes

- S
- 28
- 70
- 100
- 134
- 178
- 202

日規半密式螺桿直線電缸滑台

JP. SEMI SEALED SPINDLE AXES LINEAR ACTUATOR

- 日規電缸滑台
JP linear actuator
- 歐規電缸滑台
EU linear actuator
- 超長型電缸滑台
Super length linear actuator
- 活塞杆電動缸
Cylinder actuator
- 旋轉台
Rotary stage
- 精密對位平台
Precision alignment stage
- 減速機
Gear reducer
- 十字轉向器
Bevel gearbox
- 半密螺桿
Semi sealed spindle axes
- 全密螺桿
Sealed spindle axes
- 半密同步帶
Semi sealed toothed belt axes
- 全密同步帶
Sealed toothed belt axes



產品專利號: 2016211984545 National Patent of China

AIMS - 134 - 400 - 2010 - 2P - OL - CM - M400 - O - S3 - OIL

半密螺桿 Semi Sealed Spindle Axes	缸徑 Size (mm)	行程 Stroke (mm)	規格 Ball Screw Size (mm)	滑塊數量 Number of Slides	鎖位 Assembly Position	馬達安裝位置 Motor Position	馬達功率 Motor Power (W)	光電開關 Optical Proximity Sensor Position	開關數 Number of Sensors	自動給油 Auto Lubrication
直徑 φ	導程 Pitch	直徑 φ	導程 Pitch	2P 2個 2 Slides	OL 外鎖 Outside	CM 直接安裝 Direct	M 三菱 Mitsubishi	None	S3 3個開關 3x Sensors	
16	05	20	05	4P 4個 4 Slides	IL 內鎖 Inside	DM 下側間接 Downside Parallel	T 台達 Delta	O 外掛 Hang Outside	Sn n個開關 nx Sensors	
	10		10			LM 左側間接 Leftside Parallel	P 松下 Panasonic	I 內藏 Hide Inside		
	20		20			RM 右側間接 Rightside Parallel	O 其他 Others			
			40				Y 安川 Yaskawa			
							400			

● 有選項 Optional ● 無選項 No options

馬達輸出 Motor Power (W)	400						
額定扭矩 Torque (Nm)	1.27						
螺桿等級 Ball Screw Level	C7轉造 / C5研磨 C7 Rolled Ball Screw / C5 Ground Ball Screw						
重複定位精度 Rep. Accuracy (mm)	±0.01 / ±0.005						
螺桿規格 Ball Screw Size (mm)	φ16	05	10		20		
	φ20	05	10	20		40	
額定推力 Nominal Thrust (N)	1360	680	340	340	170		
最高速度 Max. Speed (mm/s)	250	500	1000	1000	2000		
行程範圍 Stroke Range (mm)	100...1500 / 100 間隔 Pitch						
最大 負載值 Max. Load (kg)	水平 Horizontal	2P	55	50	25	20	20
		4P	85	70	40	30	30
	側掛 Sidehang	2P	30	25	15	10	10
		4P	40	35	20	15	15
垂直 Vertical	2P	15	10	8	5	5	
	4P	20	15	10	8	8	

滑塊數量 Number of Slides	2P	4P	
力和力矩 Force and torques	F _y (N)	1080	1630
	F _z (N)	1950	2930
	M _x (N.m)	124	161
	M _y (N.m)	66	
面積二次矩 2nd moment of area	M _z (N.m)	66	
	L _{xx} (cm ²)	30	
0mm行程基本重量 Basic Weight for 0mm Stroke (kg)	L _{yy} (cm ²)	542.6	
	每100mm行程增加重量 Additional Weight per 100mm Stroke (kg)	1.4	
光電開關 Optical Proximity Sensor	SUX-PM-L45		

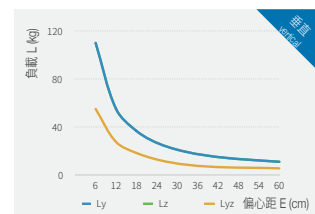
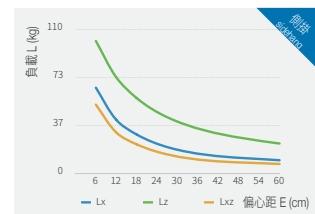
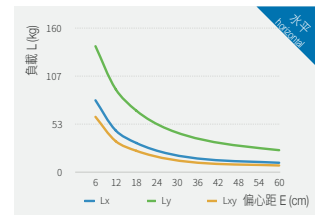

以上負載力矩曲線, 客戶選用之負載需在我司產品最大負載範圍內 Above load torque curve, the loading should be within the maximum load range

AIMS134-2P-CM 直接安裝 motor direct installed

單位 Unit: mm

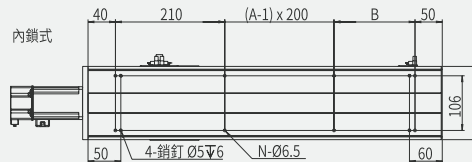
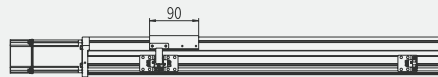
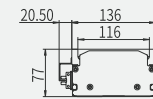
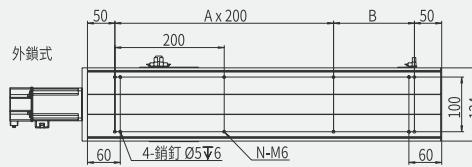
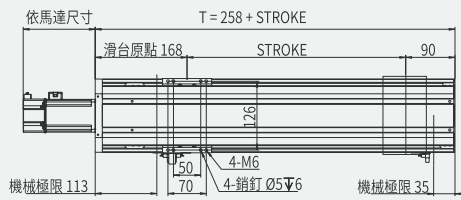

行程 Stroke	100	200	300	400	500	600	700	800	900	1000	1100	1200	1300	1400	1500
T	358	458	558	658	758	858	958	1058	1158	1258	1358	1458	1558	1658	1758
B	48	148	48	148	48	148	48	148	48	148	48	148	48	148	48
A	1	1	2	2	3	3	4	4	5	5	6	6	7	7	8
N	6	6	8	8	10	10	12	12	14	14	16	16	18	18	20
重量 Weight (Kg)	6.8	8.2	9.6	11	12.4	13.8	15.2	16.6	18	19.4	20.8	22.2	23.6	25	26.4

本圖面僅供參考用途, 實際尺寸皆以實際提供之2D/3D圖紙為準 This drawing is for reference only. The actual dimensions are based on the actual 2D / 3D drawings provided.

AIMS134-4P-CM 直接安裝 motor direct installed

單位 Unit: mm

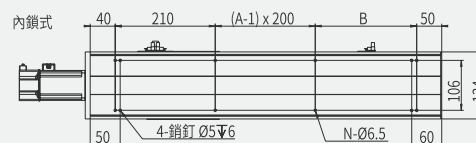
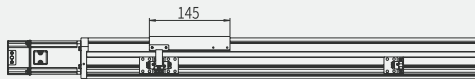
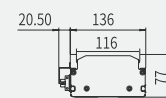
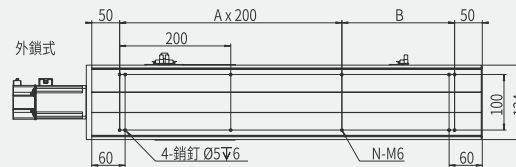
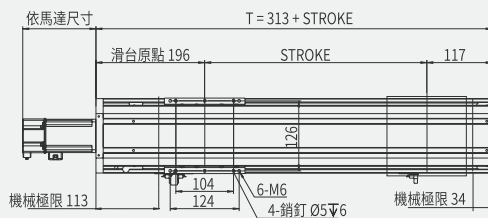

行程 Stroke	100	200	300	400	500	600	700	800	900	1000	1100	1200	1300	1400	1500
T	413	513	613	713	813	913	1013	1113	1213	1313	1413	1513	1613	1713	1813
B	103	203	103	203	103	203	103	203	103	203	103	203	103	203	103
A	1	1	2	2	3	3	4	4	5	5	6	6	7	7	8
N	6	6	8	8	10	10	12	12	14	14	16	16	18	18	20
重量 Weight (Kg)	7.8	9.2	10.6	12	13.4	14.8	16.2	17.6	19	20.4	21.8	23.2	24.6	26	27.4

本圖面僅供參考用途, 實際尺寸皆以實際提供之2D/3D圖紙為準 This drawing is for reference only. The actual dimensions are based on the actual 2D / 3D drawings provided.

 日規電缸滑台
J linear actuator

 歐規電缸滑台
EU linear actuator

 超長型電缸滑台
Super length linear actuator

 活塞杆電動缸
Cylinder actuator

 旋轉台
Rotary stage

 精密對位平台
Precision alignment stage

 減速機
Gear reducer

 十字轉向器
Bevel gearbox

 半密螺桿
Semi sealed spindle axes

 全密螺桿
Sealed spindle axes

 半密同步帶
Semi sealed toothed belt axes

 全密同步帶
Sealed toothed belt axes

S

28

70

100

134

178

202

AIMS134-2P-LM 馬達左側間接安裝 motor leftside parallel installed

單位 Unit: mm

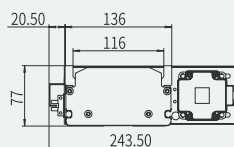
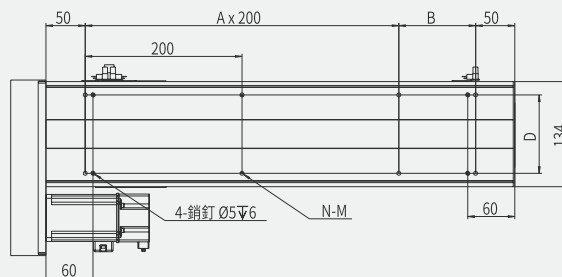
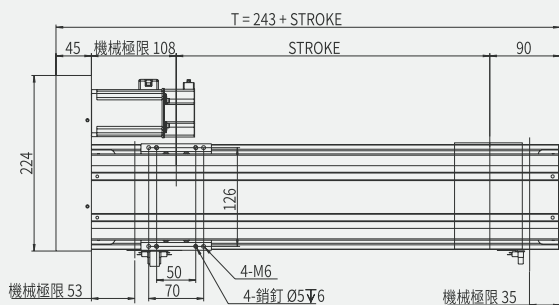

鎖位方式 Screw Method	D	M
外鎖 Exterior	100	M6
內鎖 Interior	106	Φ6.5

行程 Stroke	100	200	300	400	500	600	700	800	900	1000	1100	1200	1300	1400	1500
T	343	443	543	643	743	843	943	1043	1143	1243	1343	1443	1543	1643	1743
B	198	98	198	98	198	98	198	98	198	98	198	98	198	98	198
A	0	1	1	2	2	3	3	4	4	5	5	6	6	7	7
N	4	6	6	8	8	10	10	12	12	14	14	16	16	18	18
重量 Weight (Kg)	6.8	8.2	9.6	11	12.4	13.8	15.2	16.6	18	19.4	20.8	22.2	23.6	25	26.4

本圖面僅供參考用途，實際尺寸皆以實際提供之2D/3D圖紙為準 This drawing is for reference only. The actual dimensions are based on the actual 2D / 3D drawings provided.

AIMS134-4P-LM 馬達左側間接安裝 motor leftside parallel installed

單位 Unit: mm

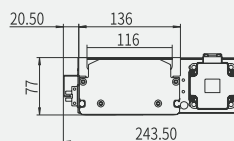
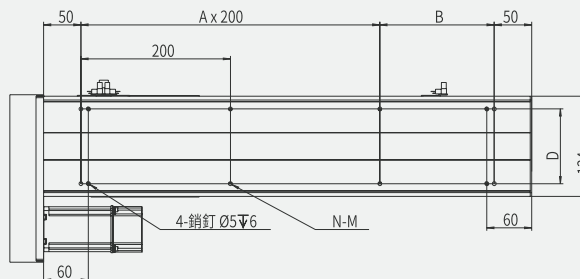
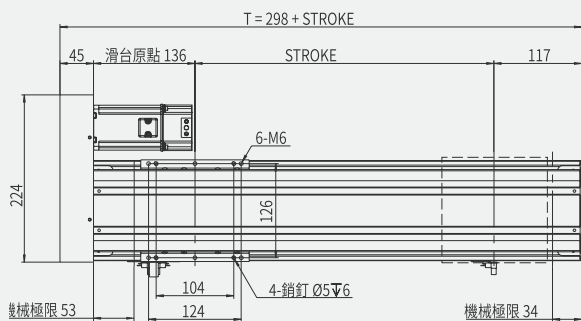

鎖位方式 Screw Method	D	M
外鎖 Exterior	100	M6
內鎖 Interior	106	Φ6.5

行程 Stroke	100	200	300	400	500	600	700	800	900	1000	1100	1200	1300	1400	1500
T	398	498	598	698	798	898	998	1098	1198	1298	1398	1498	1598	1698	1798
B	53	153	53	153	53	153	53	153	53	153	53	153	53	153	53
A	1	1	2	2	3	3	4	4	5	5	6	6	7	7	8
N	6	6	8	8	10	10	12	12	14	14	16	16	18	18	20
重量 Weight (Kg)	7.8	9.2	10.6	12	13.4	14.8	16.2	17.6	19	20.4	21.8	23.2	24.6	26	27.4

本圖面僅供參考用途，實際尺寸皆以實際提供之2D/3D圖紙為準 This drawing is for reference only. The actual dimensions are based on the actual 2D / 3D drawings provided.

S

28

70

100

134

178

202

AIMS134-2P-RM 向右間接安裝 motor rightside parallel installed

單位 Unit: mm

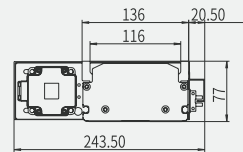
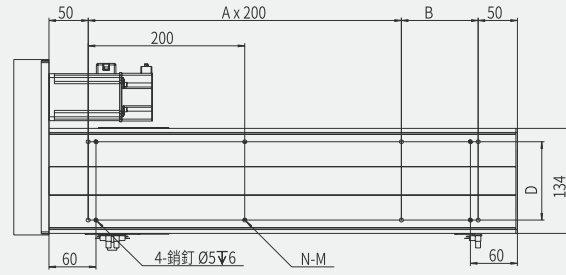
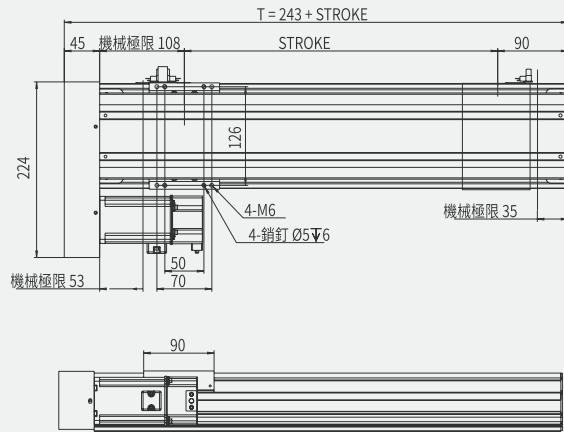

鎖位方式 Screw Method	D	M
外鎖 Exterior	100	M6
內鎖 Interior	106	Φ6.5

行程 Stroke	100	200	300	400	500	600	700	800	900	1000	1100	1200	1300	1400	1500
T	343	443	543	643	743	843	943	1043	1143	1243	1343	1443	1543	1643	1743
B	198	98	198	98	198	98	198	98	198	98	198	98	198	98	198
A	0	1	1	2	2	3	3	4	4	5	5	6	6	7	7
N	4	6	6	8	8	10	10	12	12	14	14	16	16	18	18
重量 Weight (Kg)	6.8	8.2	9.6	11	12.4	13.8	15.2	16.6	18	19.4	20.8	22.2	23.6	25	26.4

本圖面僅供參考用途，實際尺寸皆以實際提供之2D/3D圖紙為準 This drawing is for reference only. The actual dimensions are based on the actual 2D / 3D drawings provided.

AIMS134-4P-RM 向右間接安裝 motor rightside parallel installed

單位 Unit: mm

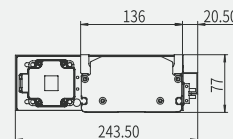
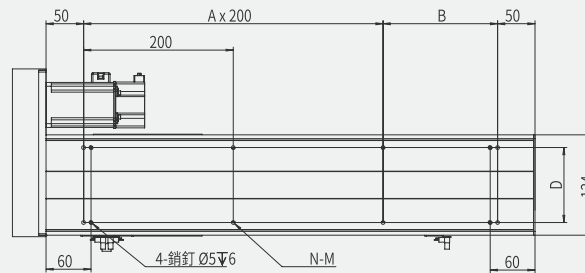
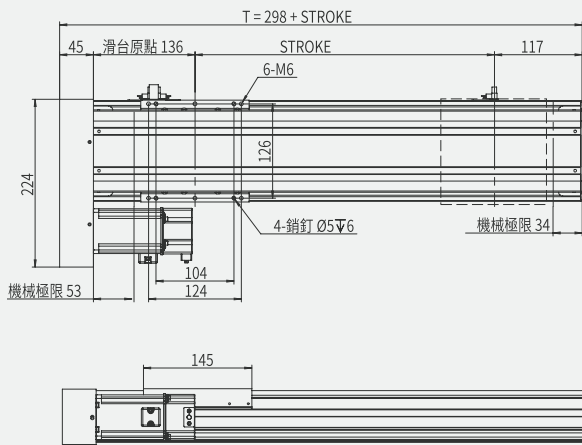

鎖位方式 Screw Method	D	M
外鎖 Exterior	100	M6
內鎖 Interior	106	Φ6.5

行程 Stroke	100	200	300	400	500	600	700	800	900	1000	1100	1200	1300	1400	1500
T	398	498	598	698	798	898	998	1098	1198	1298	1398	1498	1598	1698	1798
B	53	153	53	153	53	153	53	153	53	153	53	153	53	153	53
A	1	1	2	2	3	3	4	4	5	5	6	6	7	7	8
N	6	6	8	8	10	10	12	12	14	14	16	16	18	18	20
重量 Weight (Kg)	7.8	9.2	10.6	12	13.4	14.8	16.2	17.6	19	20.4	21.8	23.2	24.6	26	27.4

本圖面僅供參考用途，實際尺寸皆以實際提供之2D/3D圖紙為準 This drawing is for reference only. The actual dimensions are based on the actual 2D / 3D drawings provided.

- 日規電缸滑台
Linear actuator
- 歐規電缸滑台
EU linear actuator
- 超長型電缸滑台
Super length linear actuator
- 活塞杆電動缸
Cylinder actuator
- 旋轉台
Rotary stage
- 精密對位平台
Precision alignment stage
- 減速機
Gear reducer
- 十字轉向器
Bevel gearbox
- 半密螺桿
Semi sealed spindle axis
- 全密螺桿
Sealed spindle axis
- 半密同步帶
Semi sealed toothed belt axes
- 全密同步帶
Sealed toothed belt axes

- S
- 28
- 70
- 100
- 134
- 178
- 202

AIMS134-2P-DM 馬達下側間接安裝 motor downside parallel installed

單位 Unit: mm

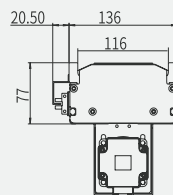
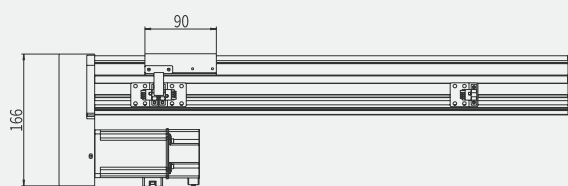
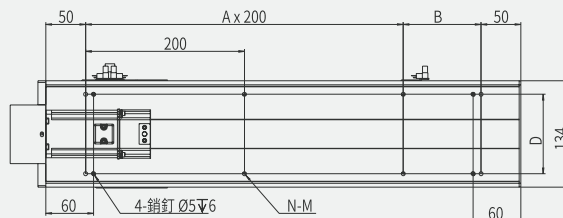
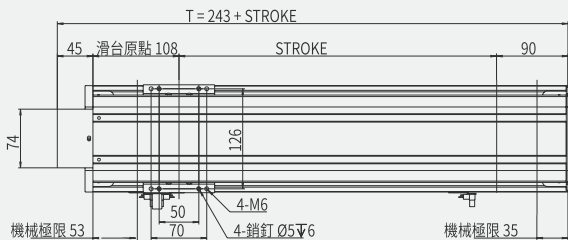

鎖位方式 Screw Method	D	M
外鎖 Exterior	100	M6
內鎖 Interior	106	Φ6.5

行程 Stroke	100	200	300	400	500	600	700	800	900	1000	1100	1200	1300	1400	1500
T	343	443	543	643	743	843	943	1043	1143	1243	1343	1443	1543	1643	1743
B	198	98	198	98	198	98	198	98	198	98	198	98	198	98	198
A	0	1	1	2	2	3	3	4	4	5	5	6	6	7	7
N	4	6	6	8	8	10	10	12	12	14	14	16	16	18	18
重量 Weight (Kg)	6.8	8.2	9.6	11	12.4	13.8	15.2	16.6	18	19.4	20.8	22.2	23.6	25	26.4

本圖面僅供參考用途，實際尺寸皆以實際提供之2D/3D圖紙為準 This drawing is for reference only. The actual dimensions are based on the actual 2D / 3D drawings provided.

AIMS134-4P-DM 馬達下側間接安裝 motor downside parallel installed

單位 Unit: mm

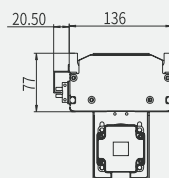
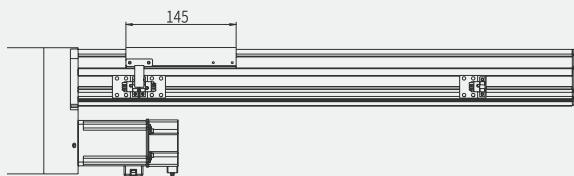
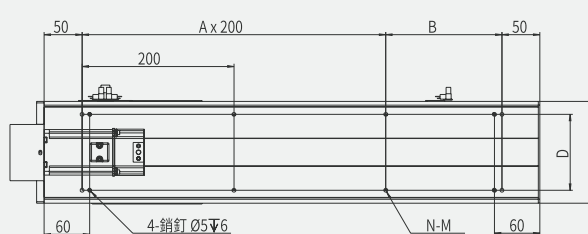
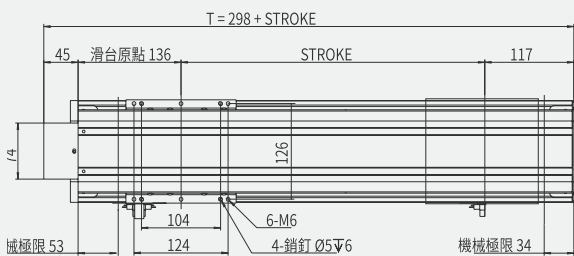

鎖位方式 Screw Method	D	M
外鎖 Exterior	100	M6
內鎖 Interior	106	Φ6.5

行程 Stroke	100	200	300	400	500	600	700	800	900	1000	1100	1200	1300	1400	1500
T	398	498	598	698	798	898	998	1098	1198	1298	1398	1498	1598	1698	1798
B	53	153	53	153	53	153	53	153	53	153	53	153	53	153	53
A	1	1	2	2	3	3	4	4	5	5	6	6	7	7	8
N	6	6	8	8	10	10	12	12	14	14	16	16	18	18	20
重量 Weight (Kg)	7.8	9.2	10.6	12	13.4	14.8	16.2	17.6	19	20.4	21.8	23.2	24.6	26	27.4

本圖面僅供參考用途，實際尺寸皆以實際提供之2D/3D圖紙為準 This drawing is for reference only. The actual dimensions are based on the actual 2D / 3D drawings provided.

S

28

70

100

134

178

202

日規半密式螺桿直線電缸滑台

JP. SEMI SEALED SPINDLE AXES LINEAR ACTUATOR



產品專利號: 2016211984545 National Patent of China

- 日規電缸滑台
JP linear actuator
- 歐規電缸滑台
EU linear actuator
- 超長型電缸滑台
Super length linear actuator
- 活塞杆電動缸
Cylinder actuator
- 旋轉台
Rotary stage
- 精密對位平台
Precision alignment stage
- 減速機
Gear reducer
- 十字轉向器
Bevel gearbox
- 半密螺桿
Semi sealed spindle axes
- 全密螺桿
Sealed spindle axes
- 半密同步帶
Semi sealed toothed belt axes
- 全密同步帶
Sealed toothed belt axes

AIMS - 178 - 400 - 2010 - 4P - OL - CM - M750 - O - S3 - OIL

半密螺桿 Semi Sealed Spindle Axes	缸徑 Size (mm)	行程 Stroke (mm)	規格 Ball Screw Size (mm)	滑塊數量 Number of Slides	鎖位 Assembly Position	馬達安裝位置 Motor Position	馬達功率 Motor Power (W)	光電開關 Optical Proximity Sensor Position	開關數 Number of Sensors	自動給油 Auto Lubrication										
直徑 φ	導程 Pitch	直徑 φ	導程 Pitch	直徑 φ	導程 Pitch	4P	4 個 4 Slides	OL	外鎖 Outside	CM	直接安裝 Direct	M	三菱 Mitsubishi	T	台達 Delta	None	S3	3 個開關 3x Sensors		
16	05	20	05	25	05			IL	內鎖 Inside	DM	下側間接 Downside Parallel	P	松下 Panasonic	O	其他 Others	O	外掛 Hang Outside	Sn	n 個開關 nx Sensors	
	10		10		10					LM	左側間接 Leftside Parallel	Y	安川 Yaskawa			I	內藏 Hide Inside			
	20		20		25					RM	右側間接 Rightside Parallel									750
			40																	

● 有選項 Optional ● 無選項 No options

馬達輸出 Motor Power (W)	750						
額定扭矩 Torque (Nm)	2.39						
螺桿等級 Ball Screw Level	C7 轉造 / C5 研磨 C7 Rolled Ball Screw / C5 Ground Ball Screw						
重複定位精度 Rep. Accuracy (mm)	±0.01 / ±0.005						
螺桿規格 Ball Screw Size (mm)	直徑 φ	導程 Pitch	直徑 φ	導程 Pitch	直徑 φ	導程 Pitch	
	Ø16	05	10	20	20	40	
	Ø20	05	10		25		
額定推力 Nominal Thrust (N)	2550	1280	640	640	510	300	
最高速度 Max. Speed (mm/s)	250	500	1000	1000	1250	2000	
行程範圍 Stroke Range (mm)	直徑 φ	0...1500 / 100 間隔 Pitch					
	Ø16	0...1500 / 100 間隔 Pitch					
	Ø20	0...2000 / 100 間隔 Pitch					
最大負載值 Max. Load (Kg)	水平 Horizontal	120	100	40	70	70	40
	側掛 Sidehang	80	70	30	40	40	30
	垂直 Vertical	50	40	20	30	30	20

滑塊數量 Number of Slides	4P	
力和力矩 Force and torques	F _y (N)	3900
	F _z (N)	9000
	M _x (N.m)	400
	M _y (N.m)	141
面積二次矩 2nd moment of area	M _z (N.m)	141
	L _{xx} (cm ²)	81.7
面積二次矩 2nd moment of area	L _{yy} (cm ²)	1515
	0mm行程基本重量 Basic Weight for 0mm Stroke (kg)	12.5
每100mm行程增加重量 Additional Weight per 100mm Stroke (kg)	2.5	
光電開關 Optical Proximity Sensor	SUX-PM-L45	

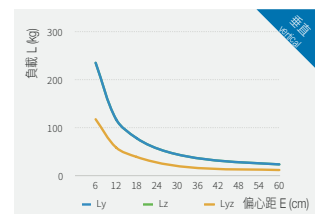
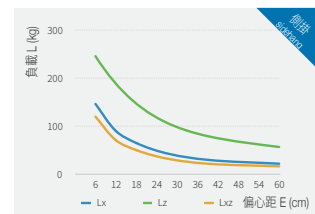
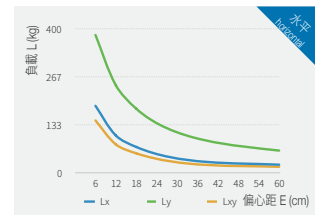

以上負載力矩曲線，客戶選用之負載需在我司產品最大負載範圍內 Above load torque curve, the loading should be within the maximum load range

- S
- 28
- 70
- 100
- 134
- 178
- 202

日規電缸滑台
JP linear actuator

歐規電缸滑台
EU linear actuator

超長型電缸滑台
Super length linear actuator

活塞杆電動缸
Cylinder actuator

旋轉台
Rotary stage

精密對位平台
Precision alignment stage

減速機
Gear reducer

十字轉向器
Bevel gearbox

半密螺桿
Semi sealed spindle axes

全密螺桿
Sealed spindle axes

半密同步帶
Semi sealed toothed belt axes

全密同步帶
Sealed toothed belt axes

AIMS178-4P-CM 直接安裝 motor direct installed

單位 Unit: mm

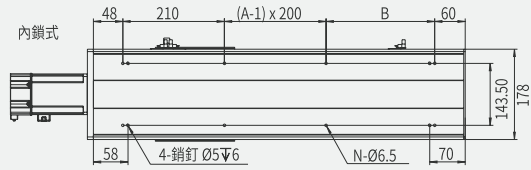
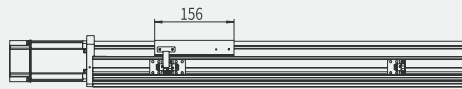
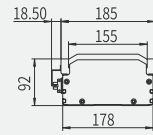
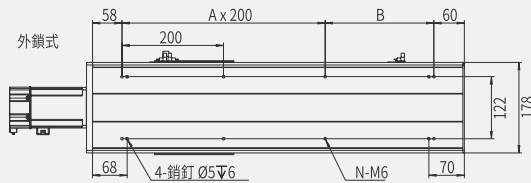
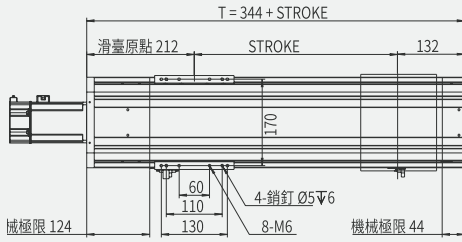

行程 Stroke	200	300	400	500	600	700	800	900	1000	1100	1200	1300	1400	1500	1600	1700	1800	1900	2000	2100	2200
T	544	644	744	844	944	1044	1144	1244	1344	1444	1544	1644	1744	1844	1944	2044	2144	2244	2344	2444	2544
B	214	114	214	114	214	114	214	114	214	114	214	114	214	114	214	114	214	114	214	114	214
A	1	2	2	3	3	4	4	5	5	6	6	7	7	8	8	9	9	10	10	11	11
N	6	8	8	10	10	12	12	14	14	16	16	18	18	20	20	22	22	24	24	26	26
重量 Weight (Kg)	16	18.5	21	23.5	26	28.5	31	33.5	36	38.5	41	43.5	46	48.5	51	53.5	56	58.5	61	63.5	66

本圖面僅供參考用途，實際尺寸皆以實際提供之2D/3D圖紙為準 This drawing is for reference only. The actual dimensions are based on the actual 2D / 3D drawings provided.

AIMS178-4P-LM 馬達左側間接安裝 motor leftside parallel installed

單位 Unit: mm

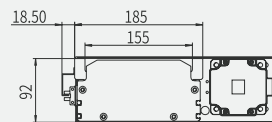
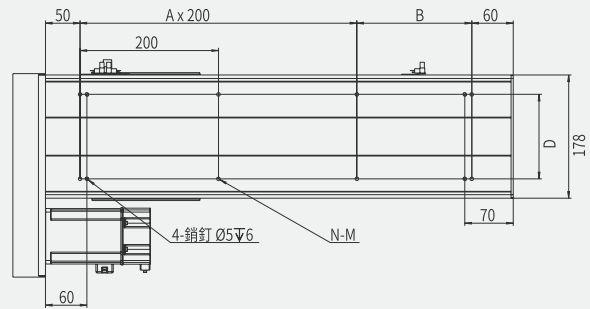
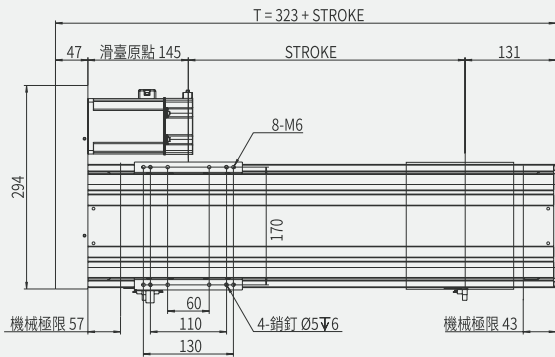

鎖位方式 Screw Method	D	M
外鎖 Exterior	122	M6
內鎖 Interior	143.5	Φ6.5

行程 Stroke	200	300	400	500	600	700	800	900	1000	1100	1200	1300	1400	1500	1600	1700	1800	1900	2000	2100	2200
T	523	623	723	823	923	1023	1123	1223	1323	1423	1523	1623	1723	1823	1923	2023	2123	2223	2323	2423	2523
B	166	66	166	66	166	66	166	66	166	66	166	66	166	66	166	66	166	66	166	66	166
A	1	2	2	3	3	4	4	5	5	6	6	7	7	8	8	9	9	10	10	11	11
N	6	8	8	10	10	12	12	14	14	16	16	18	18	20	20	22	22	24	24	26	26
重量 Weight (Kg)	15	17.5	20	22.5	25	27.5	30	32.5	35	37.5	40	42.5	45	47.5	50	52.5	55	57.5	60	62.5	65

本圖面僅供參考用途，實際尺寸皆以實際提供之2D/3D圖紙為準 This drawing is for reference only. The actual dimensions are based on the actual 2D / 3D drawings provided.

S

28

70

100

134

178

202

AIMS178-4P-RM 向右間接安裝 motor rightside parallel installed

單位 Unit: mm

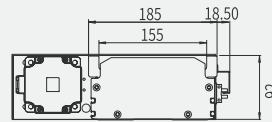
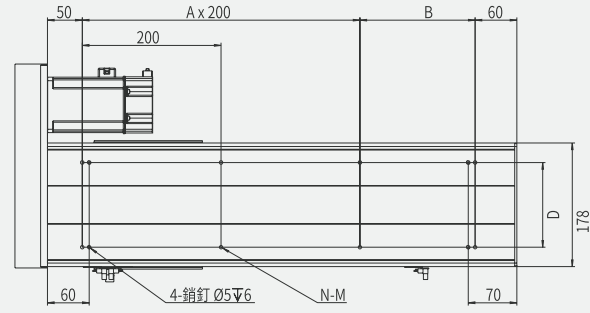
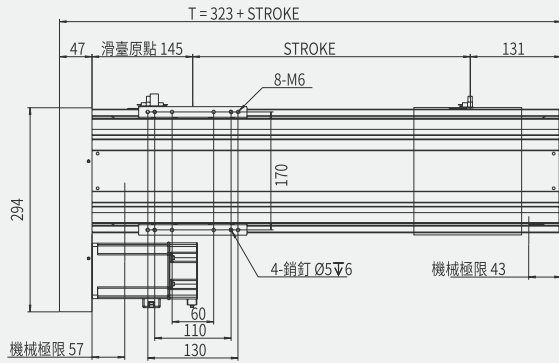

鎖位方式 Screw Method	D	M
外鎖 Exterior	122	M6
內鎖 Interior	143.5	Φ6.5

行程 Stroke	200	300	400	500	600	700	800	900	1000	1100	1200	1300	1400	1500	1600	1700	1800	1900	2000	2100	2200
T	523	623	723	823	923	1023	1123	1223	1323	1423	1523	1623	1723	1823	1923	2023	2123	2223	2323	2423	2523
B	166	66	166	66	166	66	166	66	166	66	166	66	166	66	166	66	166	66	166	66	166
A	1	2	2	3	3	4	4	5	5	6	6	7	7	8	8	9	9	10	10	11	11
N	6	8	8	10	10	12	12	14	14	16	16	18	18	20	20	22	22	24	24	26	26
重量 Weight (Kg)	15	17.5	20	22.5	25	27.5	30	32.5	35	37.5	40	42.5	45	47.5	50	52.5	55	57.5	60	62.5	65

本圖面僅供參考用途, 實際尺寸皆以實際提供之2D/3D圖紙為準 This drawing is for reference only. The actual dimensions are based on the actual 2D / 3D drawings provided.

AIMS178-4P-DM 馬達下側間接安裝 motor downside parallel installed

單位 Unit: mm

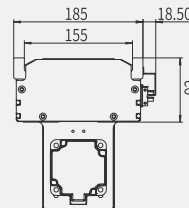
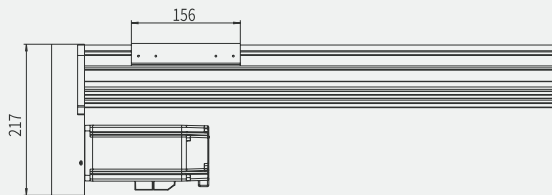
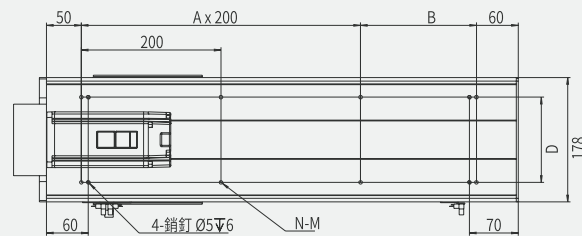
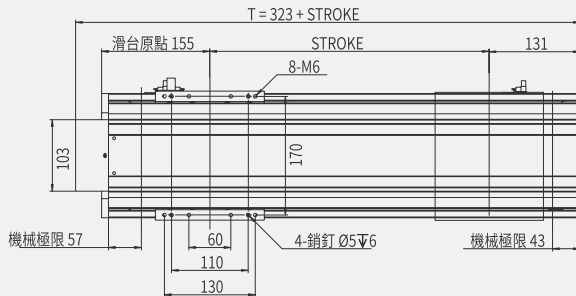

鎖位方式 Screw Method	D	M
外鎖 Exterior	122	M6
內鎖 Interior	143.5	Φ6.5

行程 Stroke	200	300	400	500	600	700	800	900	1000	1100	1200	1300	1400	1500	1600	1700	1800	1900	2000	2100	2200
T	523	623	723	823	923	1023	1123	1223	1323	1423	1523	1623	1723	1823	1923	2023	2123	2223	2323	2423	2523
B	166	66	166	66	166	66	166	66	166	66	166	66	166	66	166	66	166	66	166	66	166
A	1	2	2	3	3	4	4	5	5	6	6	7	7	8	8	9	9	10	10	11	11
N	6	8	8	10	10	12	12	14	14	16	16	18	18	20	20	22	22	24	24	26	26
重量 Weight (Kg)	15	17.5	20	22.5	25	27.5	30	32.5	35	37.5	40	42.5	45	47.5	50	52.5	55	57.5	60	62.5	65

本圖面僅供參考用途, 實際尺寸皆以實際提供之2D/3D圖紙為準 This drawing is for reference only. The actual dimensions are based on the actual 2D / 3D drawings provided.

- 日規電缸滑台
Linear actuator
- 歐規電缸滑台
EU linear actuator
- 超長型電缸滑台
Super length linear actuator
- 活塞杆電動缸
Cylinder actuator
- 旋轉台
Rotary stage
- 精密對位平台
Precision alignment stage
- 減速機
Gear reducer
- 十字轉向器
Bevel gearbox

- 半密螺桿
Semi sealed spindle axis
- 全密螺桿
Sealed spindle axis
- 半密同步帶
Semi sealed toothed belt axes
- 全密同步帶
Sealed toothed belt axes

- S
- 28
- 70
- 100
- 134
- 178
- 202

日規半密式螺桿直線電缸滑台

JP. SEMI SEALED SPINDLE AXES LINEAR ACTUATOR

- 日規電缸滑台
JP linear actuator
- 歐規電缸滑台
EU linear actuator
- 超長型電缸滑台
Super length linear actuator
- 活塞杆電動缸
Cylinder actuator
- 旋轉台
Rotary stage
- 精密對位平台
Precision alignment stage
- 減速機
Gear reducer
- 十字轉向器
Bevel gearbox
- 半密螺桿
Semi sealed spindle axes
- 全密螺桿
Sealed spindle axes
- 半密同步帶
Semi sealed toothed belt axes
- 全密同步帶
Sealed toothed belt axes



產品專利號: 2016211984545 National Patent of China

AIMS - 202 - 400 - 2510 - 4P - OL - CM - M750 - O - S3 - OIL

半密螺桿 Semi Sealed Spindle Axes	缸徑 Size (mm)	行程 Stroke (mm)	規格 Ball Screw Size (mm)	滑塊數量 Number of Slides	鎖位 Assembly Position	馬達安裝位置 Motor Position	馬達功率 Motor Power (W)	光電開關 Optical Proximity Sensor Position	開關數 Number of Sensors	自動給油 Auto Lubrication
	直徑 Φ	導程 Pitch	直徑 Φ	4P 4 個 4 Slides	OL 外鎖 Outside IL 內鎖 Inside	CM 直接安裝 Direct DM 下側間接 Downside Parallel LM 左側間接 Leftside Parallel RM 右側間接 Rightside Parallel	M 三菱 Mitsubishi T 台達 Delta P 松下 Panasonic O 其他 Others Y 安川 Yaskawa	None O 外掛 Hang Outside I 內藏 Hide Inside	S3 3 個開關 3x Sensors Sn n 個開關 nx Sensors	
	25	05 10 25	32 20 32				750			

● 有選項 Optional ● 無選項 No options

馬達輸出 Motor Power (W)	750					
額定扭矩 Torque (Nm)	2.39					
螺桿等級 Ball Screw Level	C7 轉造 / C5 研磨 C7 Rolled Ball Screw / C5 Ground Ball Screw					
重複定位精度 Rep. Accuracy (mm)	±0.01 / ±0.005					
螺桿規格 Ball Screw Size (mm)	Ø25	05	10	25	25	32
	Ø32	05	10	20		32
額定推力 Nominal Thrust (N)	2560	1280	640	510	260	
最高速度 Max. Speed (mm/s)	250	500	1000	1250	2500	
行程範圍 Stroke Range (mm)	Ø25	100...2000 / 100 間隔 Pitch				
	Ø32					
最大負載值 Max. Load (Kg)	水平 Horizontal	140	120	75	75	50
	側掛 Sidehang	100	80	60	50	40
	垂直 Vertical	70	60	30	30	20

滑塊數量 Number of Slides	4P	
力和力矩 Force and torques	F _y (N)	4500
	F _z (N)	14247
	M _x (N.m)	800
	M _y (N.m)	160
	M _z (N.m)	160
	面積二次矩 2nd moment of area	L _{xx} (cm ²)
L _{yy} (cm ²)		2354
0mm行程基本重量 Basic Weight for 0mm Stroke (kg)	12.5	
每100mm行程增加重量 Additional Weight per 100mm Stroke (kg)	2.5	
光電開關 Optical Proximity Sensor	SUX-PM-L45	

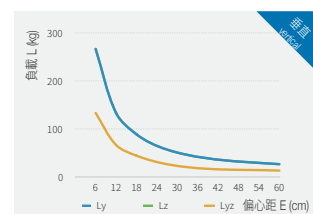
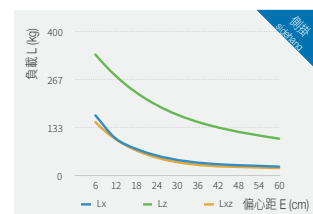
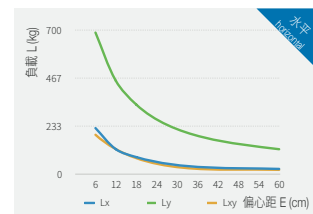

以上負載力矩曲線，客戶選用之負載需在我司產品最大負載範圍內 Above load torque curve, the loading should be within the maximum load range

AIMS202-4P-CM 直接安裝 motor direct installed

單位 Unit: mm

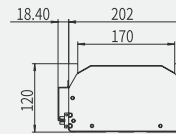
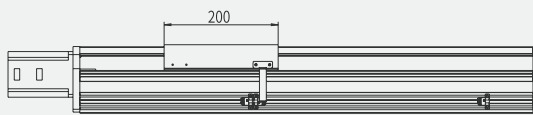
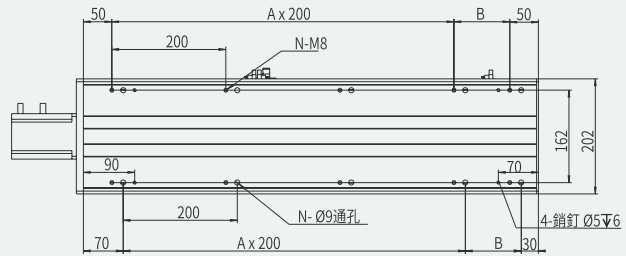
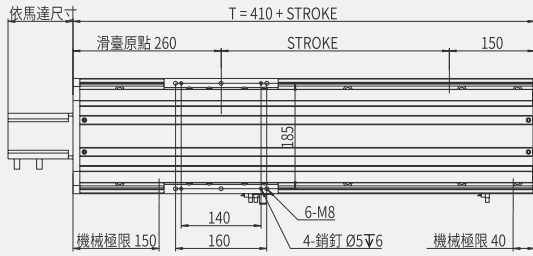

行程 Stroke	200	300	400	500	600	700	800	900	1000	1100	1200	1300	1400	1500	1600	1700	1800	1900	2000	2100	2200
T	610	710	810	910	1010	1110	1210	1310	1410	1510	1610	1710	1810	1910	2010	2110	2210	2310	2410	2510	2610
B	98	198	98	198	98	198	98	198	98	198	98	198	98	198	98	198	98	198	98	198	98
A	2	2	3	3	4	4	5	5	6	6	7	7	8	8	9	9	10	10	11	11	12
N	8	8	10	10	12	12	14	14	16	16	18	18	20	20	22	22	24	24	26	26	28
重量 Weight (Kg)	18.3	21.3	24.3	27.3	30.3	33.3	36.3	39.3	42.3	45.3	48.3	51.3	54.3	57.3	60.3	63.3	66.3	69.3	72.3	75.3	78.3

本圖面僅供參考用途，實際尺寸皆以實際提供之2D/3D圖紙為準 This drawing is for reference only. The actual dimensions are based on the actual 2D / 3D drawings provided.

AIMS202-4P-LM 馬達左側間接安裝 motor leftside parallel installed

單位 Unit: mm

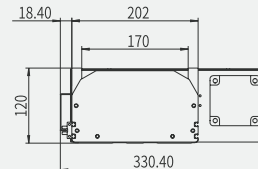
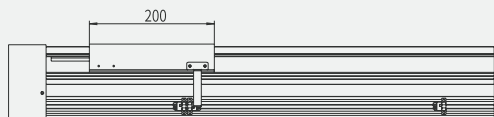
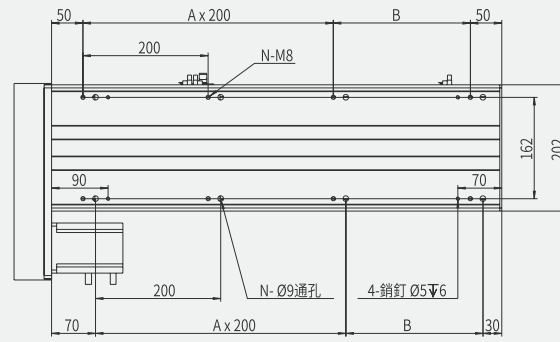
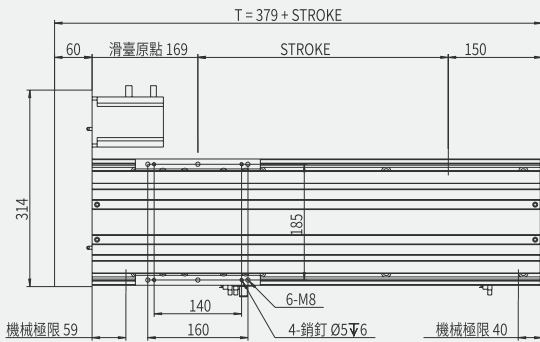

行程 Stroke	200	300	400	500	600	700	800	900	1000	1100	1200	1300	1400	1500	1600	1700	1800	1900	2000	2100	2200
T	579	679	779	879	979	1079	1179	1279	1379	1479	1579	1679	1779	1879	1979	2079	2179	2279	2379	2479	2579
B	219	119	219	119	219	119	219	119	219	119	219	119	219	119	219	119	219	119	219	119	219
A	1	2	2	3	3	4	4	5	5	6	6	7	7	8	8	9	9	10	10	11	11
N	6	8	8	10	10	12	12	14	14	16	16	18	18	20	20	22	22	24	24	26	26
重量 Weight (Kg)	19.5	22.5	25.5	28.5	31.5	34.5	37.5	40.5	43.5	46.5	49.5	52.5	55.5	58.5	61.5	64.5	67.5	70.5	73.5	76.5	79.5

本圖面僅供參考用途，實際尺寸皆以實際提供之2D/3D圖紙為準 This drawing is for reference only. The actual dimensions are based on the actual 2D / 3D drawings provided.

- 日規電缸滑台
Linear actuator
- 歐規電缸滑台
EU linear actuator
- 超長型電缸滑台
Super length linear actuator
- 活塞杆電動缸
Cylinder actuator
- 旋轉台
Rotary stage
- 精密對位平台
Precision alignment stage
- 減速機
Gear reducer
- 十字轉向器
Bevel gearbox
- 半密螺桿
Semi sealed spindle axis
- 全密螺桿
Sealed spindle axis
- 半密同步帶
Semi sealed toothed belt axis
- 全密同步帶
Sealed toothed belt axis

- S
- 28
- 70
- 100
- 134
- 178
- 202

日規電缸滑台
JP linear actuator

歐規電缸滑台
EU linear actuator

超長型電缸滑台
Super length linear actuator

活塞杆電動缸
Cylinder actuator

旋轉台
Rotary stage

精密對位平台
Precision alignment stage

減速機
Gear reducer

十字轉向器
Bevel gearbox

半密螺桿
Semi sealed spindle axes

全密螺桿
Sealed spindle axes

半密同步帶
Semi sealed toothed belt axes

全密同步帶
Sealed toothed belt axes

AIMS202-4P-RM 向右間接安裝 motor rightside parallel installed

單位 Unit: mm

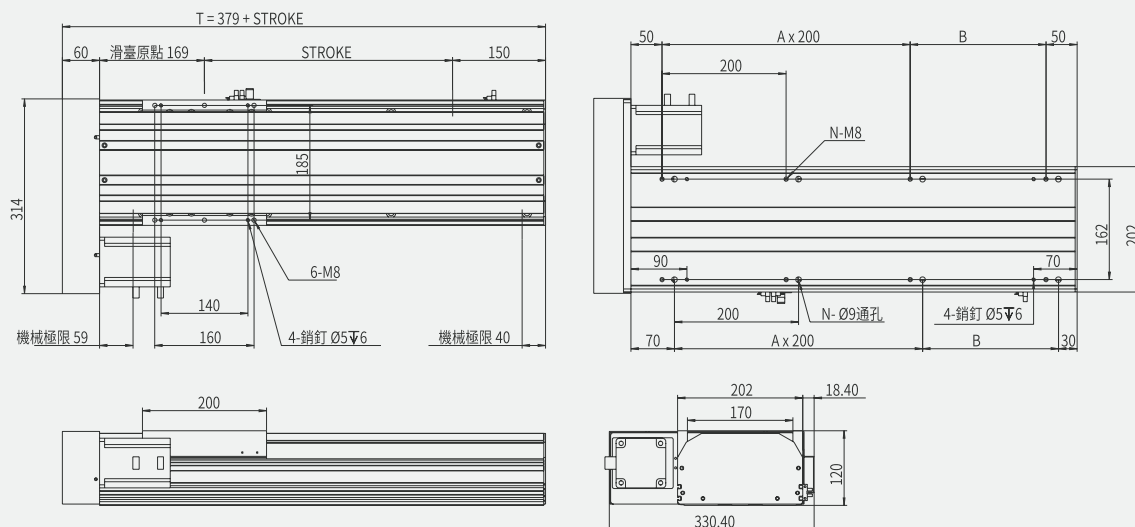

行程 Stroke	200	300	400	500	600	700	800	900	1000	1100	1200	1300	1400	1500	1600	1700	1800	1900	2000	2100	2200
T	579	679	779	879	979	1079	1179	1279	1379	1479	1579	1679	1779	1879	1979	2079	2179	2279	2379	2479	2579
B	219	119	219	119	219	119	219	119	219	119	219	119	219	119	219	119	219	119	219	119	219
A	1	2	2	3	3	4	4	5	5	6	6	7	7	8	8	9	9	10	10	11	11
N	6	8	8	10	10	12	12	14	14	16	16	18	18	20	20	22	22	24	24	26	26
重量 Weight (Kg)	19.5	22.5	25.5	28.5	31.5	34.5	37.5	40.5	43.5	46.5	49.5	52.5	55.5	58.5	61.5	64.5	67.5	70.5	73.5	76.5	79.5

本圖面僅供參考用途，實際尺寸皆以實際提供之2D/3D圖紙為準 This drawing is for reference only. The actual dimensions are based on the actual 2D / 3D drawings provided.

AIMS202-4P-DM 馬達下側間接安裝 motor downside parallel installed

單位 Unit: mm

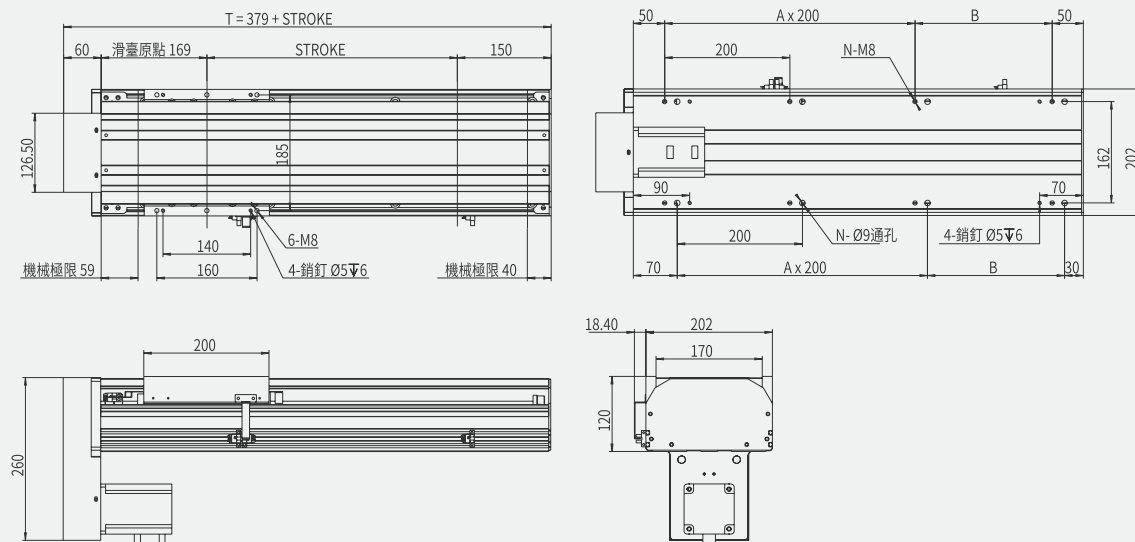

行程 Stroke	200	300	400	500	600	700	800	900	1000	1100	1200	1300	1400	1500	1600	1700	1800	1900	2000	2100	2200
T	579	679	779	879	979	1079	1179	1279	1379	1479	1579	1679	1779	1879	1979	2079	2179	2279	2379	2479	2579
B	219	119	219	119	219	119	219	119	219	119	219	119	219	119	219	119	219	119	219	119	219
A	1	2	2	3	3	4	4	5	5	6	6	7	7	8	8	9	9	10	10	11	11
N	6	8	8	10	10	12	12	14	14	16	16	18	18	20	20	22	22	24	24	26	26
重量 Weight (Kg)	19.5	22.5	25.5	28.5	31.5	34.5	37.5	40.5	43.5	46.5	49.5	52.5	55.5	58.5	61.5	64.5	67.5	70.5	73.5	76.5	79.5

本圖面僅供參考用途，實際尺寸皆以實際提供之2D/3D圖紙為準 This drawing is for reference only. The actual dimensions are based on the actual 2D / 3D drawings provided.

S

28

70

100

134

178

202



日規電缸滑台 J linear actuator
歐規電缸滑台 EU linear actuator
超長型電缸滑台 Super length linear actuator
活塞杆電動缸 Cylinder actuator
旋轉台 Rotary stage
精密對位平台 Precision alignment stage
減速機 Gear reducer
十字轉向器 Bevel gearbox
半密螺桿 Semi sealed spindle axes
全密螺桿 Sealed spindle axes
半密同步帶 Semi sealed toothed belt axes
全密同步帶 Sealed toothed belt axes

S

28
70
100
134
178
202